

BPH-E / DPH-E DIALOGUE ELECTRONIC CIRCULATORS FOR HEATING AND CONDITIONING SYSTEMS

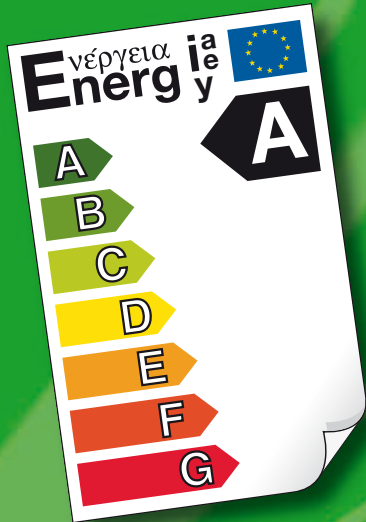

NEW

DAB
PUMP PERFORMANCE

BPH-E DPH-E DIALOGUE

The **DIALOGUE BPH-E e DPH-E** family of electronic circulators represents the most innovative circulation pump electronic applications for heating and air conditioning systems.

The **DIALOGUE BPH-E e DPH-E** circulators incorporate an electronic device that allows constant pressure regulation, proportional pressure regulation (consequently constant flow rate) and constant operating curve.

Furthermore, some functions can be interpolated with the temperature of the liquid.

SIMPLIFIED INSTALLATION

- Front user interface: simple and functional
- PN6/PN10 series flanging: maximum flexibility



STRAIGHTFORWARD MANAGEMENT

- A wide range of applications: a unique and ideal heating and air conditioning product (liquid temp. from -10 to +120°C) with an ample selection of models
- **DIALOGUE**: has everything for a generous selection of functions

TRANQUILLITY AND RESPECT OF THE ENVIRONMENT

- Reduction of the system's overpressure and reduction of noise and vibrations
- Considerable increase of the circulator's average life: used only if the system requires it
- Respect of the environment and reduction of the polluting emissions thanks to notable energy saving

EFFORTLESS MAINTENANCE

- Sturdy and reliable construction: guaranteed by the "plug and play" installation
- Simplified service: simple and fast alarms memory

BPH-E DPH-E DIALOGUE

APPLICATIONS

DIALOGUE electronic circulation pumps can be used in the heating, ventilation and air conditioning systems of apartment and office blocks such as:

- High-rise apartments
- Houses
- Schools
- Properties
- Apartment blocks
- Clinics and hospitals
- Buildings adapted for offices

All models are available both in the single version as well as in the back-up twin version

HEATING APPLICATIONS

Heating required in different applications varies significantly during the day/night due to the outside temperature and by the more or less presence of people within the rooms. In addition to this, the different requirements of the various locations and possible opening and closing of the various branches in complex systems must also be considered.

In practically all correctly dimensioned systems the electronically regulated wet rotor pumps constantly ensure a sufficient amount of energy as well as less noise and greater comfort in addition to a considerable reduction in the running costs. In order to reduce further loss in the single version circulator pump casing, the insulation should ideally be used, which can be ordered as an accessory and supplied separately.

AIR CONDITIONING APPLICATIONS

Unlike conventional electronic pumps, the **DIALOGUE** electronic circulation pumps can also be used in air conditioning systems where the temperature of the pumped liquid is lower than the ambient temperature. In these circumstances, condensation forms on the outer casing of the circulator that does not influence the correct functioning of the electronic and mechanical parts. The particular construction has been designed and assessed in order to allow the drainage of the condensate without damaging the structural components.

For the thermal insulation of the circulator's pump casing with the separately supplied insulating shells (for the single version only – the insulating shells must be specially made for the back-up twin versions), take care not to block the discharge labyrinths so as not to impair its performance.

STRUCTURAL CHARACTERISTICS

Enbloc circulation pump made up of cast iron hydraulic parts and an electric asynchronous motor with wet rotor. Aluminium motor casing. High performance volute pump casing thanks to the detailed design and smooth internal surfaces. In-line suction and delivery ports, flanged with threaded connectors for the introduction of the temperature and pressure sockets. Technopolymer rotor, hardened stainless steel motor shaft mounted on graphite bushings that are lubricated by the pumped liquid. Stainless steel rotor and stator liner.

Ceramic thrust washer, ethylene propylene grommet and brass air vent cap. Two pole asynchronous motor.

An automatic type clapet valve is foreseen on the back-up twin version that is incorporated into the delivery port to prevent the circulation of water when the unit is idle. Furthermore, a blank flange is also supplied if one of the two motors requires maintenance.

The standard PN10 production of the pump casing is compatible with PN6 counterflanges for the interchangeability of the pump on existing systems. The DN 80 PN 16 version (eight holes) can be supplied on request.

Circulator protection class: IP 44 Insulation class: H

Standard voltage: 230V, 50/60 Hz single-phase

The product complies with the EN 61800-3 – EN 60335-1 – EN 60335-2-51 European standards

DIALOGUE STRUCTURAL CHARACTERISTICS (Electronic devices)

For greater efficiency and strength, the **DIALOGUE** circulators are controlled by a IGBT based device with the latest NPT technology. The specific characteristics are as follows:

- sinusoidal PWM modulation
- High carrier frequency to eliminate any audio band noise
- 32 bit dedicated DPS processor
- “space vector” optimized algorithm

Setting has been made user friendly thanks to an intuitive and functional user interface. The simplified backlit display on the control panel, with three simple navigation keys, a pull-down menu in line with the latest mobile phone trends, and a wide range of functions make the BPH-E **DIALOGUE** circulator a revolutionary product.

A reliable a sturdy construction combined to the modern and innovative design completes the product even from an aesthetical point of view.

BPH-E DPH-E DIALOGUE

OPERATING MODES

All operations listed below can be consulted by all users (even those less qualified) by means of the Dialogue menu. Access to the settings and modification of the parameters is protected and reserved for qualified users only.

1 - Constant differential pressure regulation mode $\Delta P-c$

The $\Delta P-c$ regulation mode maintains the system's differential pressure constant at the set value H_{setp} based on the varying flow rate.

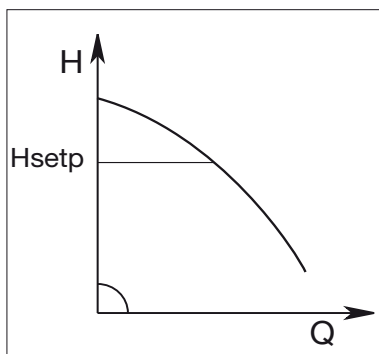

This regulation is particularly suitable for the following systems:

a. Dual pipe heating systems with thermostatic valves and:

- head less than 2 meters;
- natural circulation;
- low head loss in the parts of the system where the total quantity of water flows;
- high differential temperature (central heating).

b. Floor heating systems with thermostatic valves

c. Single pipe heating systems with thermostatic valves and adjustment valves

d. Systems with primary circuit pumps with low head loss

2 - Proportional differential pressure regulation mode $\Delta P-v$

The $\Delta P-v$ regulation mode, based on the changing flow rate, linearly varies the delivery value of the head from H_{setp} to $H_{setp}/2$.

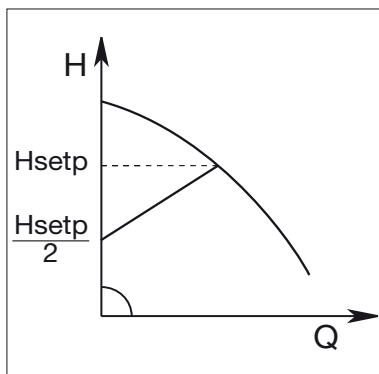

This regulation is particularly suitable for the following systems:

a. Dual pipe heating systems with thermostatic valves and:

- head over 4 meters;
- exceptionally long piping;
- valves with a wide operating range;
- differential pressure regulator;
- high head loss in the parts of the system where the total quantity of water flows;
- low differential temperature

b. Floor heating systems and systems with thermostatic valves and high head loss in the boiler circuit.

c. Systems with primary circuit pumps with high head loss.

3 - Constant curve regulation mode

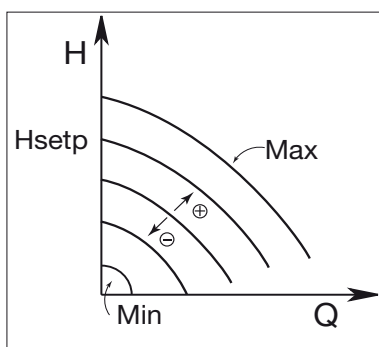

The regulation at constant speed deactivates the regulation of the electronic module. The speed of the pump can be manually regulated at a constant value through the control panel, remote control or by a 0-10V signal where:

$V \leq 3$ Volt the rotation speed is 846 rpm (min speed)

$V = 10$ Volt the rotation speed is 2820 rpm (max speed)

For V between 3 and 10 Volt linear interpolation of the speed.

This type of regulation is particularly suitable for circulators in already existing systems.

BPH-E DPH-E DIALOGUE

4 - Proportional and constant differential pressure regulation mode based on the water temperature

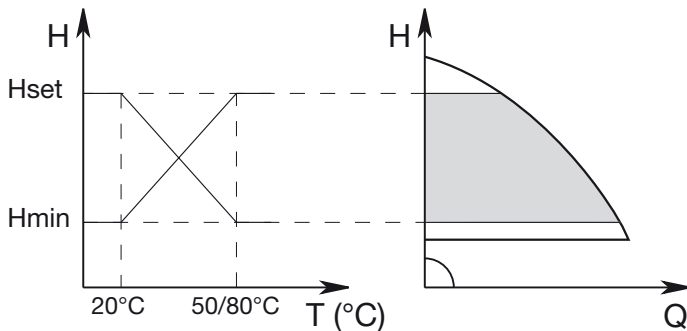

The Setpoint related to the head of the circulator is reduced and increased based on the water temperature.

The temperature of the liquid can be set at 80°C or 50°C.

This type of regulation is particularly suitable for the following systems:

- in systems with a variable flow rate (dual pipe heating systems), where a further reduction of the circulator's performance is ensured due to the drop in temperature of the circulating liquid when less heating is required.
- in systems with a constant flow rate (single pipe and floor heating systems), where the performance of the circulator can be regulated only when the temperature change function is activated.

This is set by means of the control unit on the lid of the **DIALOGUE** device.

ECONOMY MODE

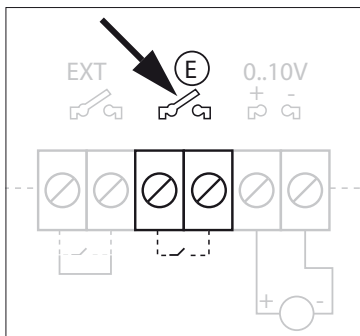

The economy mode can be set directly from the control panel by setting the reduction value (f.rid) that can have a maximum value of 50%.

The following values are replaced in all the previously listed settings:

Hset
to a value of
 $Hset \times f.rid$

ALARMS MANAGEMENT

The **DIALOGUE** device can remotely reactivate the alarms that have occurred in the pump itself through a clean contact (250Vac – 5 Amp). These alarms are also memorised in the resident memory for subsequent consultation. The alarms archive can also be cancelled to perform dedicated tests.

ALARMS DISPLAY

Symbol	Alarm Type	Symbol	Alarm Type
	E01 "Pump blocked"		W01 "No sensor signal"
	E02 "Internal error V18"		W02 "No back-up twin communication"
	E03 "Low mains voltage" (LP)		W03 "Overheating of electronic parts"
	E04 "High mains voltage" (HP)		W04 "Cooling system failure"
	E06 "Critical overheating of electronic parts"		

BPH-E DPH-E DIALOGUE

ELECTRICAL CONNECTIONS

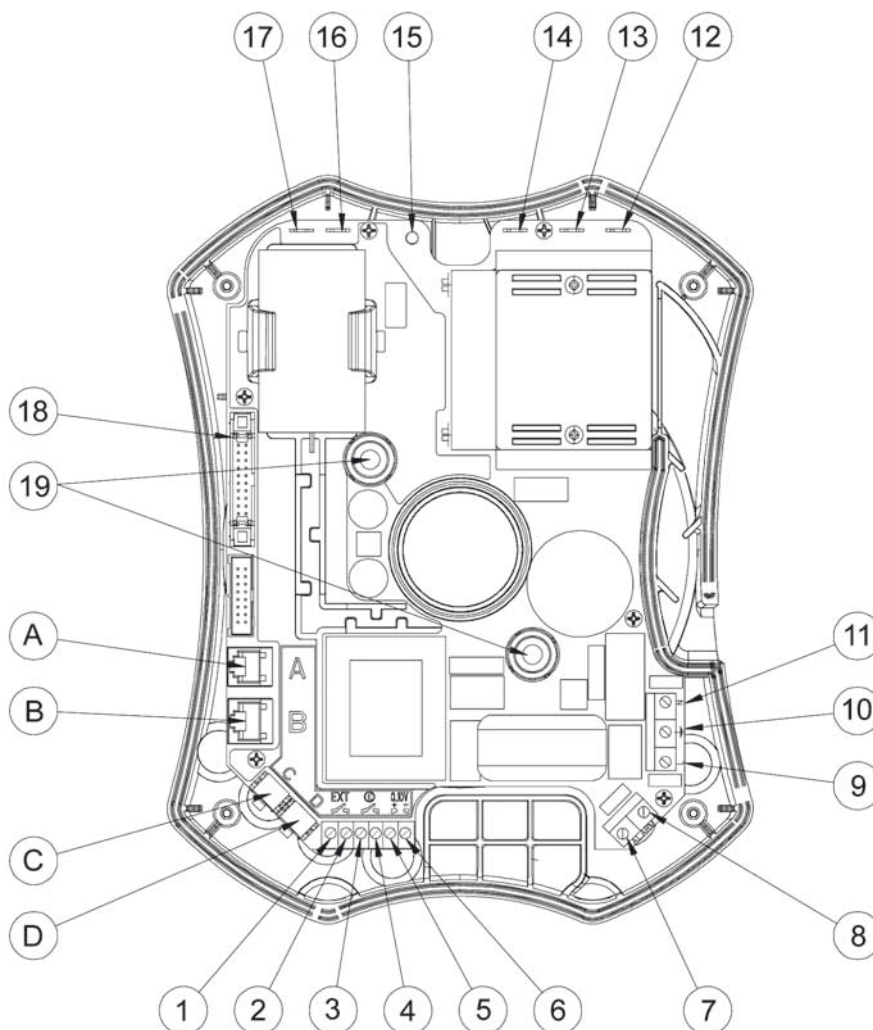

Rif.	FUNCTION
A	Remote control connection connector RS485
B	Twin circulator connection connector
C	Remote control connection connector (optional)
D	Sockets connection connector
1 - 2 (exit)	Remote control connection terminal
3 - 4 (ⓔ)	Economy mode input connection terminals
5 - 6 (0 - 10V)	Analogue input connection terminals 0-10V dc rif. 5 = +10V rif. 6 = 0V
7 - 8 (ALARM)	Remote alarm contact connection terminals 250V ac 5A
9 - 10 - 11	Power supply connection terminals 1x230V 50-60Hz rif. 9 = Live rif. 10 = Earth rif. 11 = Neutral
12 - 13 - 14	Faston for motor cables connections rif. 12 = red cable rif. 13 = green cable rif. 14 = white cable
15	Screw for connection to earth
16 - 17	Faston for connection to motoprotector – white cable
18	Connection connector display Dialogue
19	Screws

BPH-E DPH-E DIALOGUE

DIALOGUE DISPLAY - THE SETTING PARAMETERS

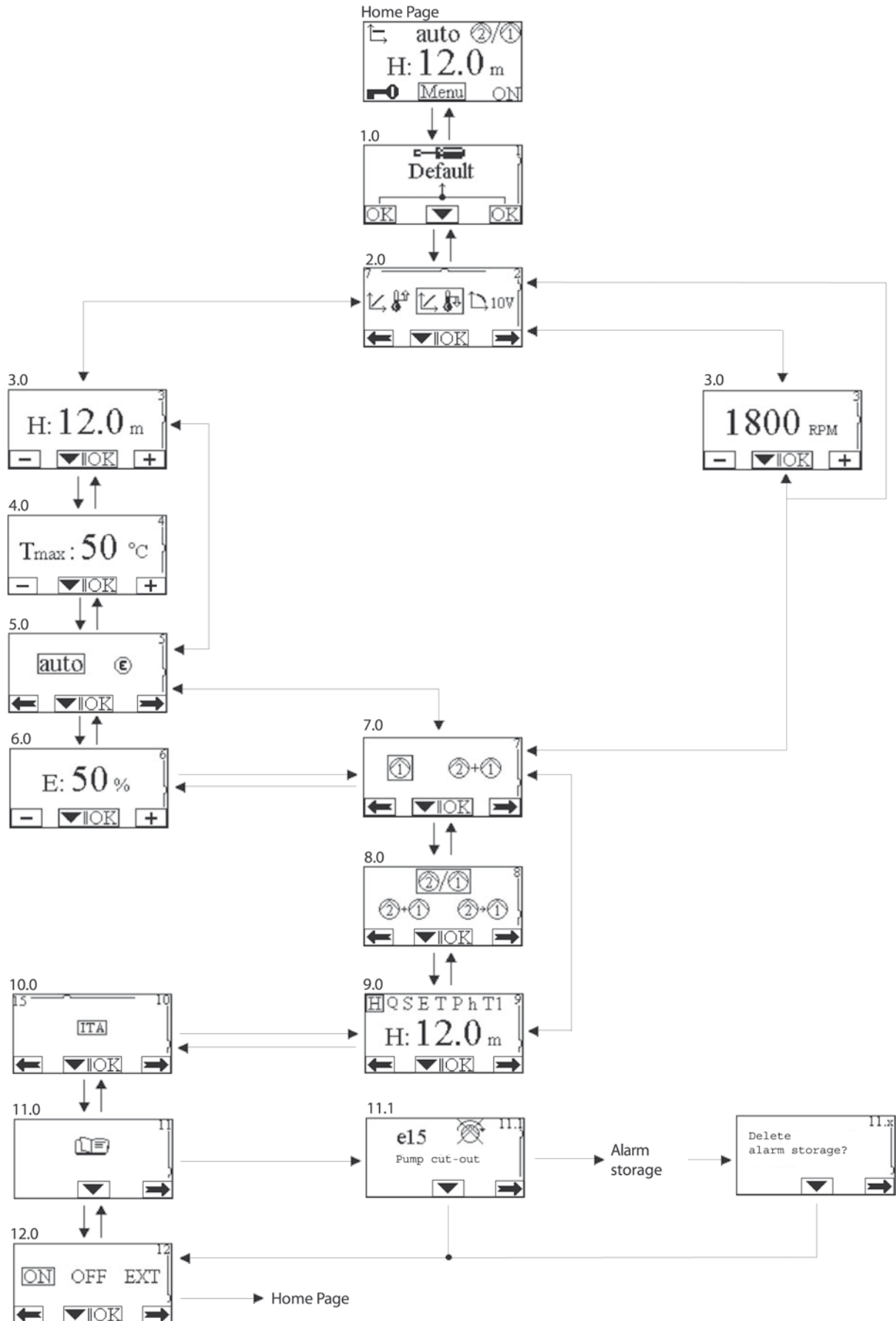

BPH-E DPH-E DIALOGUE

SYMBOLS AND DESCRIPTIONS

Symbol	Description
H Q S E T P h T1	Parameters
H:	Head (m)
Q:	Flow (m ³ /h)
S:	Speed (rpm)
E:	Analogue input 0-10V
T:	Liquid temperature (°C) – input D
P:	Power (kW)
h:	Elapsed time
T1:	Liquid temperature (°C) – input C
T _{max} :	Max liquid temperature (°C) according to regulation mode

Status:

Symbol	Description
①	Single circulator or nr. 1
②	Circulator nr. 2
②/①	Twin circulator (alternating) (switch every 24 hours)
②+①	Twin circulator main/reserve
②+①	Twin circulator (simult)
ON	
OFF	
EXT	Remote control connection

Operating mode:

Symbol	Description
auto	Automatic mode
E	Economy mode

Regulation mode:

Symbol	Description
↔	Mode Δp -c
↔ ↑	Mode Δp -c (Increasing temp)
↔ ↓	Mode Δp -c (Decreasing temp)
↙	Mode Δp -v
↙ ↑	Mode Δp -v (Increasing temp)
↙ ↓	Mode Δp -v (Decreasing temp)
↘	Servo-motor regulation (speedy set by display)
↘ 10V	Servo-motor regulation (speedy set by remote control 0-10V)

Miscellaneous:

Symbol	Description
🔑	Control panel blocked
▼IOK / ▲IOK	Setting keys

INSTALLATION

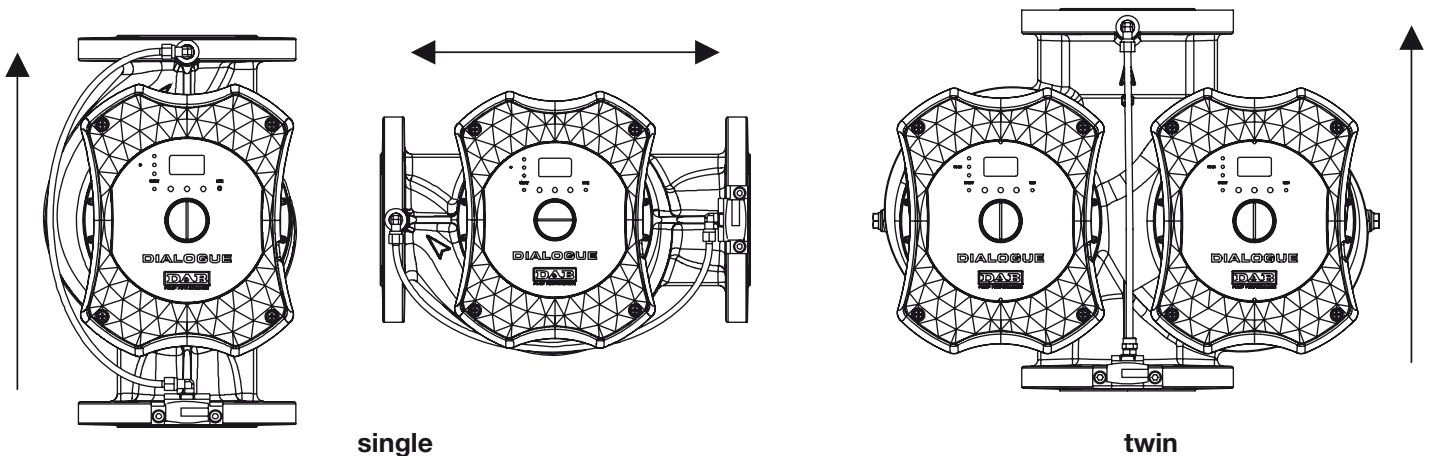

single

twin

BPH-E DPH-E DIALOGUE

DENOMINATION INDEX:

(example)

B P H - E 120 / 250 . 40 M

B = single circulator
D = twin circulator
M = 4-pole motor
P = 2-pole motor
H = suitable for both heating and air conditioning
E = electronic **DIALOGUE**

maximum head (dm)

axes centres (mm)

(DN) nominal diameter of the flanged ports

M = single-phase motor

TECHNICAL DATA

N.	PARTS	MATERIALS
1	PUMP BODY	CAST IRON 200 UNI ISO 185
4	IMPELLER	TECHNOPOLYMER B
7A	MOTOR SHAFT	STAINLESS STEEL AISI 420 C
7B	ROTOR	-
8	STATOR	-
10	MOTOR CASING	DIE CAST ALUMINIUM
11	AIR OUTLET CAP	BRASS P Cu Zn 40 Pb2 UNI 5705
127	SEAL RING	E.P.D.M.
128	STATOR SLEEVE	STAINLESS STEEL AISI 321 - AISI 304
130	CLOSING FLANGE	CAST IRON 200 UNI ISO 185
131	THRUST BOX SUPPORT	STAINLESS STEEL AISI 304 L
132	BRUSHINGS	CARBON EC 941

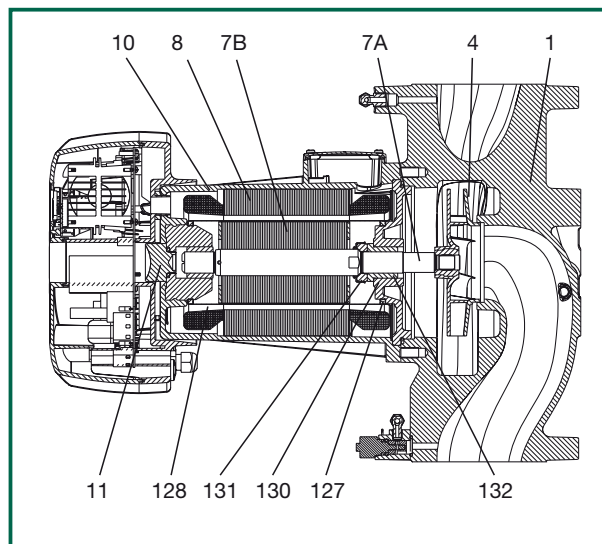

Operating range:	from 11,8 to 72 m ³ /h with head up to 18 metres;
Liquid temperature range:	from -10 °C to +120 °C
Liquid quality requirements:	clean, free from solids, not viscous, not aggressive and close to the characteristics of water. (glycole max 30%).
Maximum operating pressure:	10 bar (1000 kPa)
Flanging:	DN 40, DN 50, DN 65, PN 10 (4 holes), DN 80 in PN 6 / 10 (4 holes)
Minimum head pressure:	see tables.
Special versions on request:	Flanging - DN 80 in PN 10 / PN 16 (8 holes)
Accessories:	Counterflange PN 10 / DN 40 - DN 50 - DN 65 - DN 80.

BPH-E 60/250.40 M

Characteristic curves $\Delta p-c$ (constant)

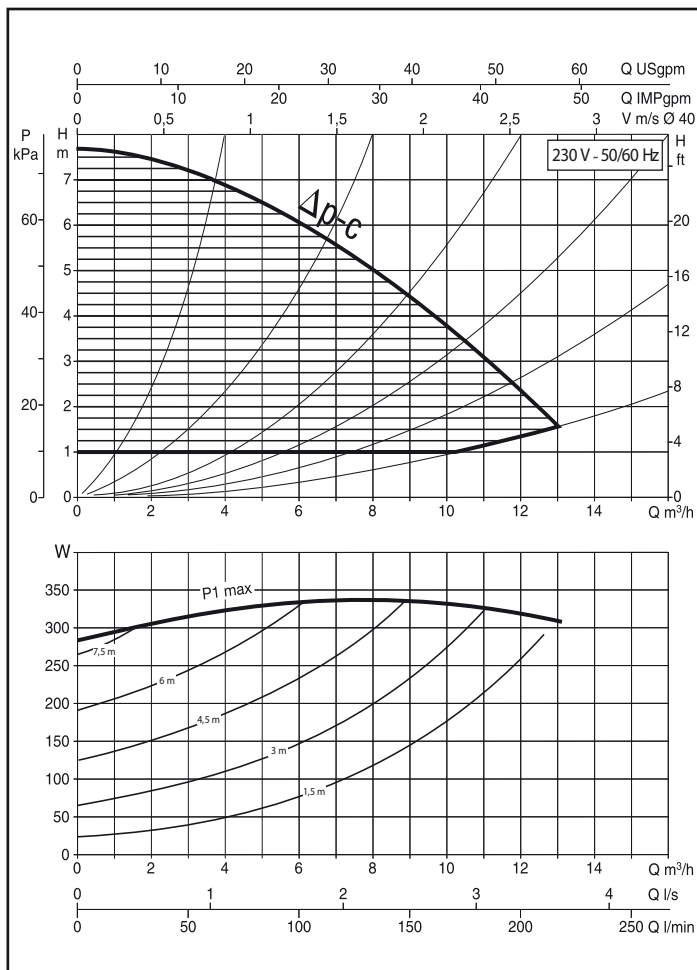

Characteristic curves $\Delta p-v$ (variable)

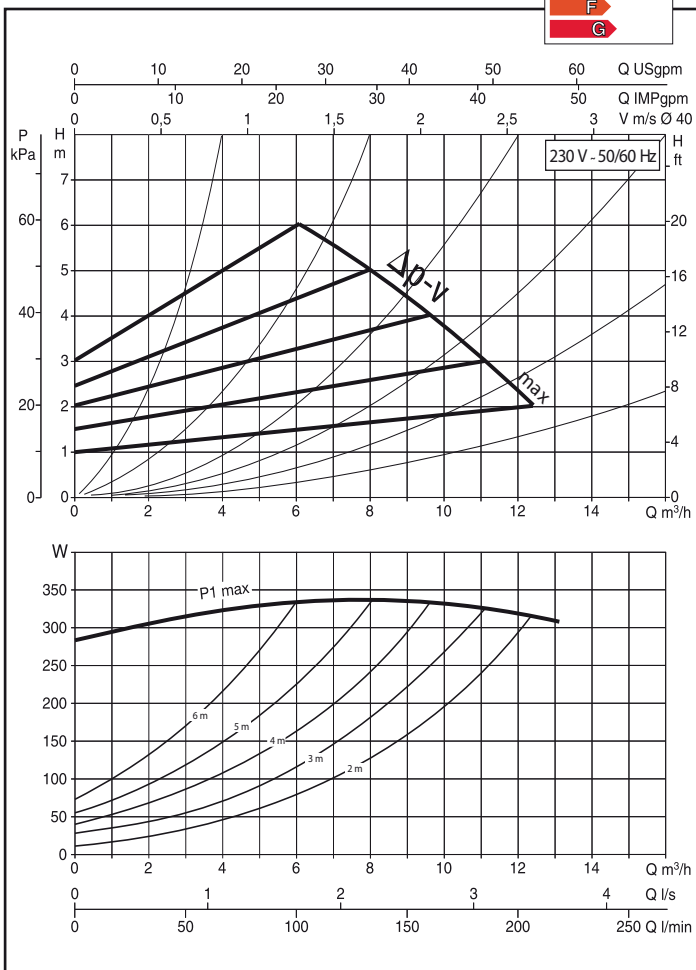

Dimensions

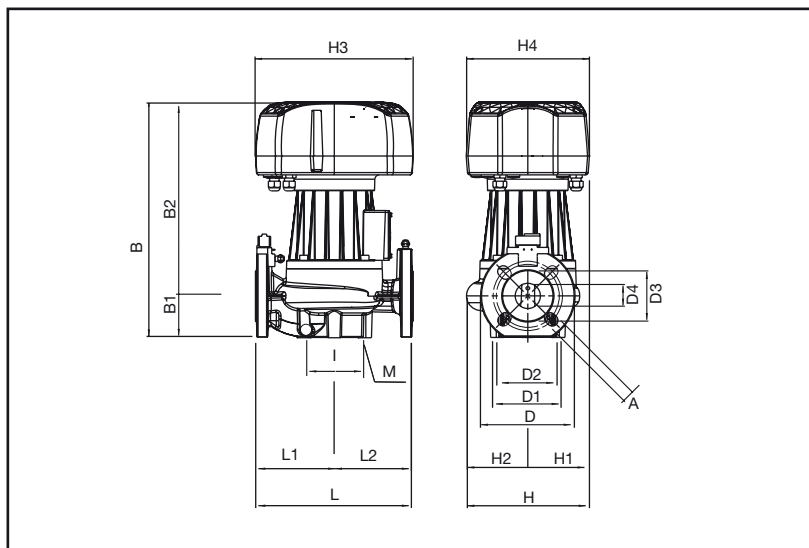

Terminals block layout

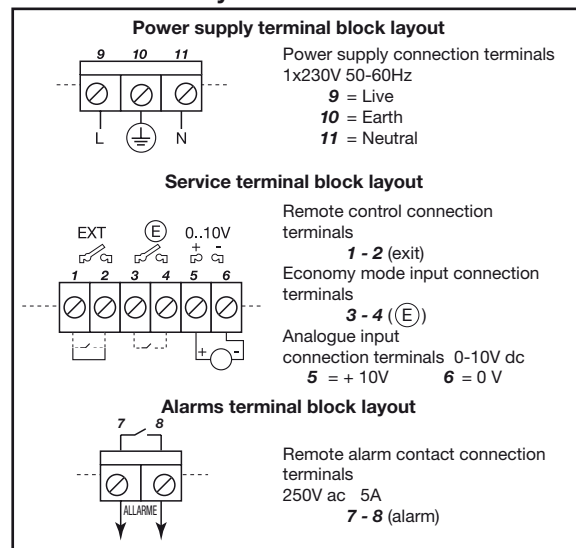

Dimensions

L	L1	L2	A	B	B1	B2	D	D1	D2	D3	D4	I	I1	I2	I3	M	H	H1	H2	H3	H4	VOLUME m ³	WEIGHT Kg
250	125	125	18	374	66	308	150	110	100	80	40	100	-	-	-	M10	195	83	112	250	196	0,053	17,7

Electrical data

MODEL	VOLTAGE 50/60 Hz	CENTRE DISTANCE mm	FLANGES ON REQUEST	ELECTRICAL DATA		MINIMUM HEAD PRESSURE			
				P1 MAX W	I _n A	t° m.t.	75°	90°	110°
BPH-E 60/250-40	230 V	250	DN 40 - PN 10	344	2	1,6	4	-	19

DPH-E 60/250.40 M

Characteristic curves $\Delta p-c$ (constant)

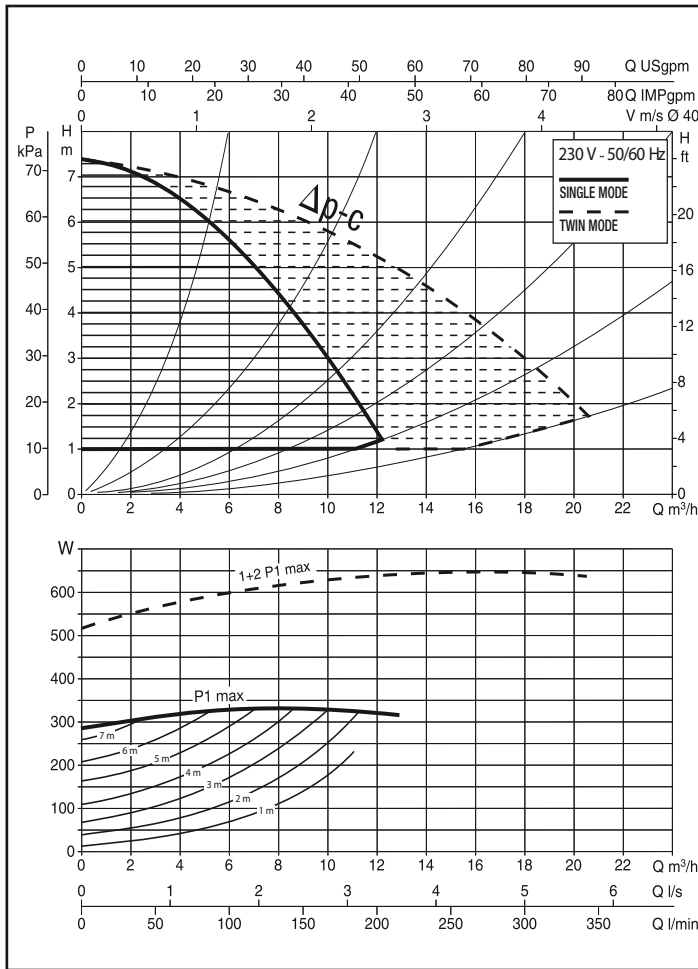

Characteristic curves $\Delta p-v$ (variable)

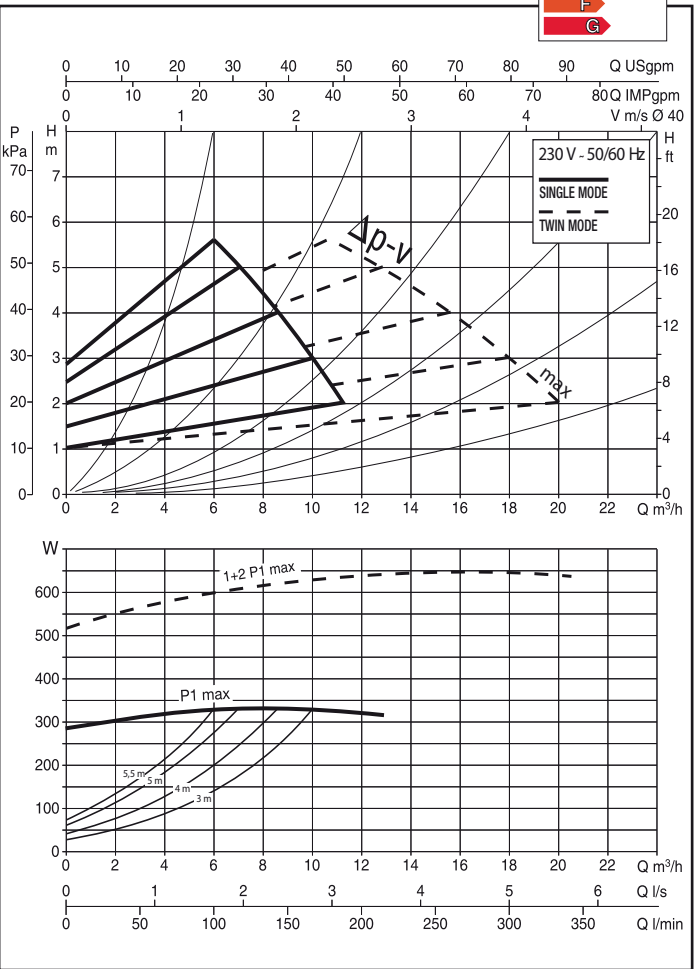

Dimensions

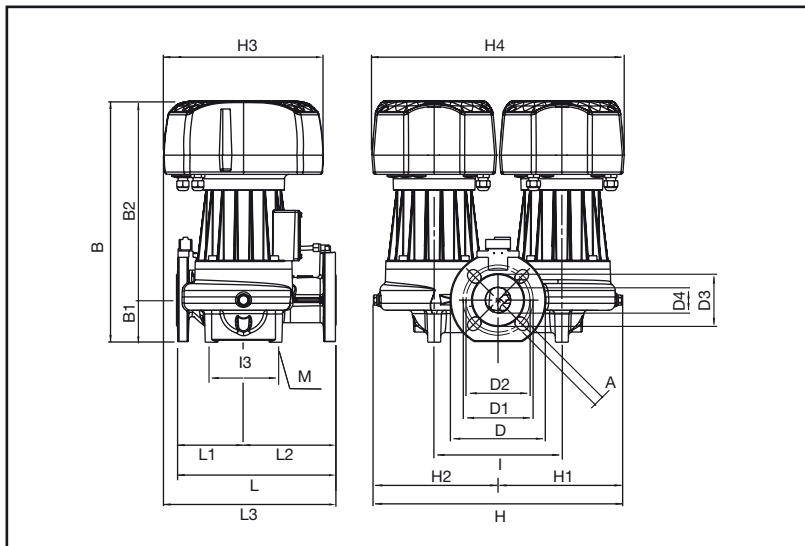

Dimensions

L	L1	L2	L3	A	B	B1	B2	D	D1	D2	D3	D4	I	I1	I2	I3	M	H	H1	H2	H3	H4	VOLUME m³	WEIGHT Kg
250	105	145	270	18	378	66	312	150	110	100	80	40	200	100	100	100	M12	389	194,5	195	250	396	0,143	42,7

Electrical data

MODEL	VOLTAGE 50/60 Hz	CENTRE DISTANCE mm	FLANGES ON REQUEST	ELECTRICAL DATA		MINIMUM HEAD PRESSURE
				P1 MAX W	In A	
DPH-E 60/250-40	230 V	250	DN 40 - PN 10	344	2	t° 75° 90° 110° 120° m.t. 1,6 4 - 19

Terminals block layout

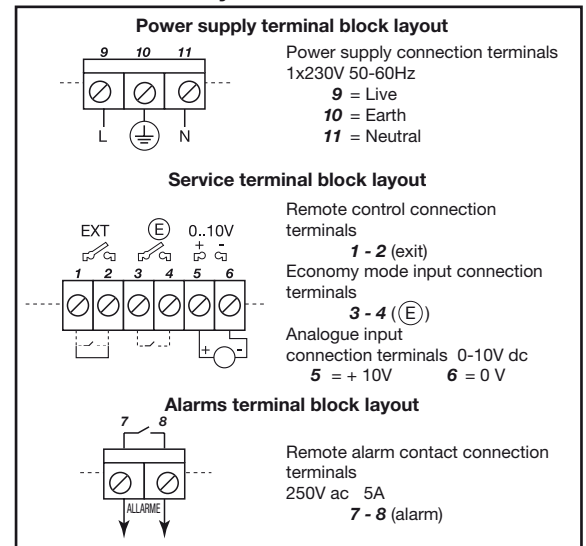

BPH-E 120/250.40 M

Characteristic curves $\Delta p-c$ (constant)

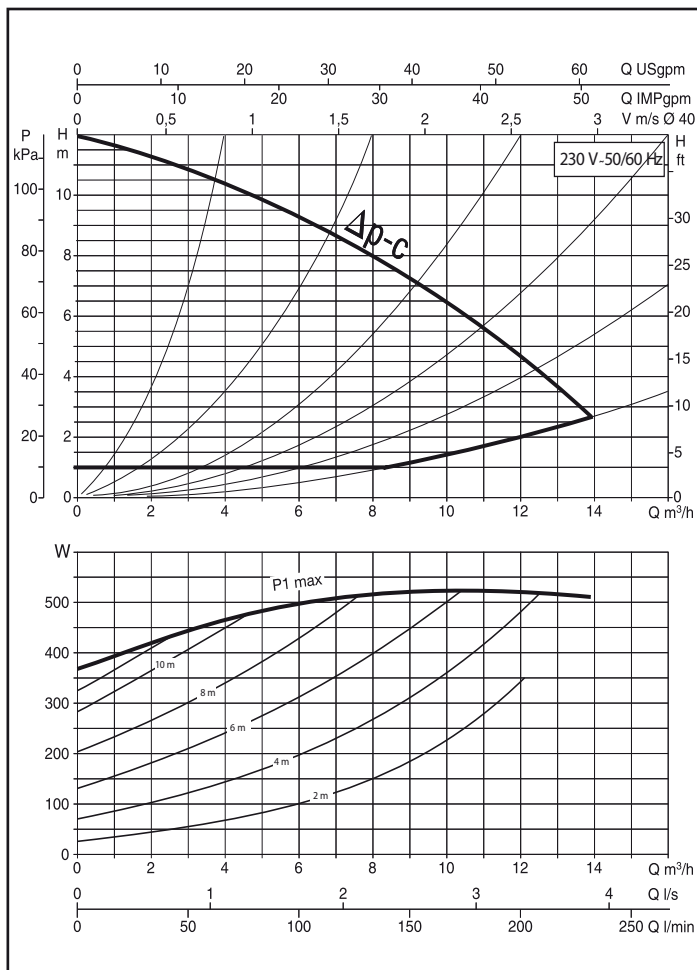

Characteristic curves $\Delta p-v$ (variable)

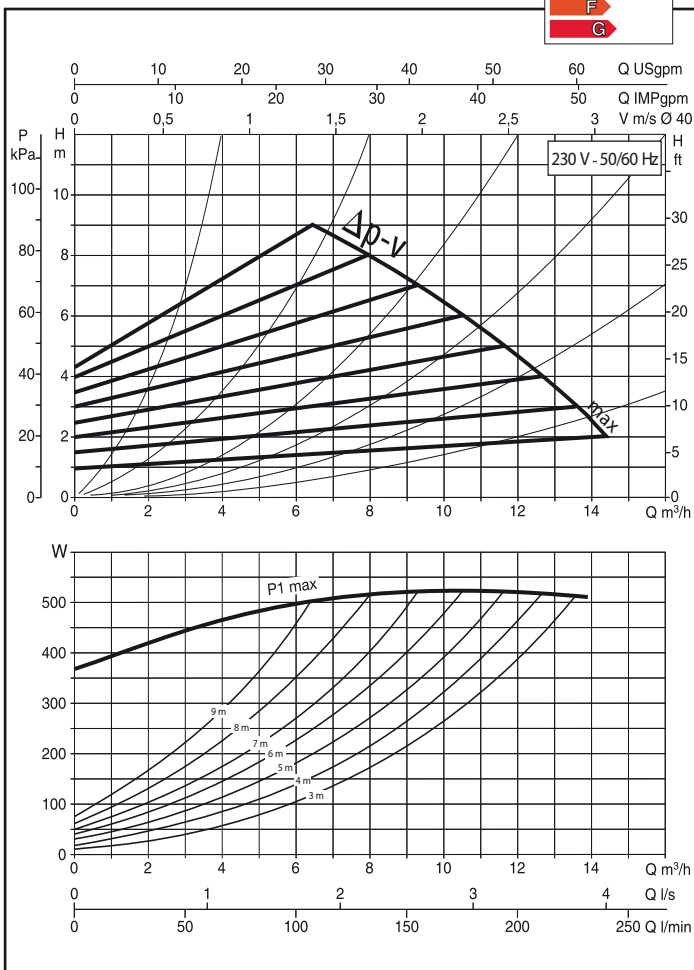

Dimensions

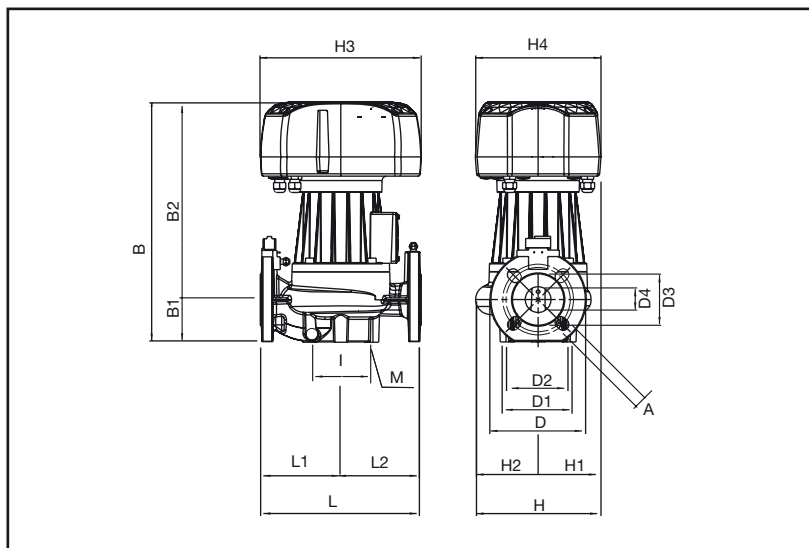

Terminals block layout

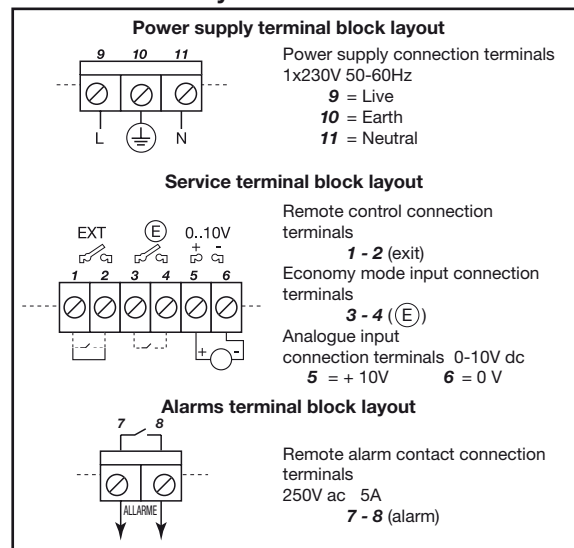

Dimensions

L	L1	L2	A	B	B1	B2	D	D1	D2	D3	D4	I	I1	I2	I3	M	H	H1	H2	H3	H4	VOLUME m ³	WEIGHT Kg
250	125	125	18	374	66	308	150	100	100	80	40	100	-	-	-	M10	195	83	112	250	196	0,053	21,7

Electrical data

MODEL	VOLTAGE 50/60 Hz	CENTRE DISTANCE mm	FLANGES ON REQUEST	ELECTRICAL DATA		MINIMUM HEAD PRESSURE				
				P1 MAX W	I _n A	t° m.t.	75°	90°	110°	120°
BPH-E 120/250-40	230 V	250	DN 40 - PN 10	528	3	6	9	-	23	

DPH-E 120/250.40 M

Characteristic curves $\Delta p-c$ (constant)

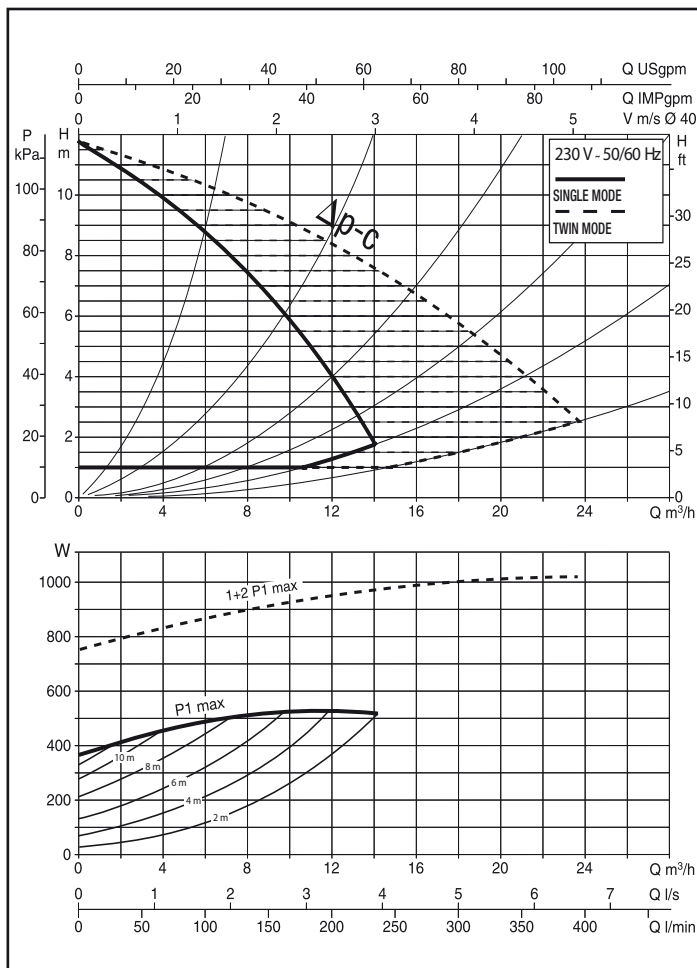

Characteristic curves $\Delta p-v$ (variable)

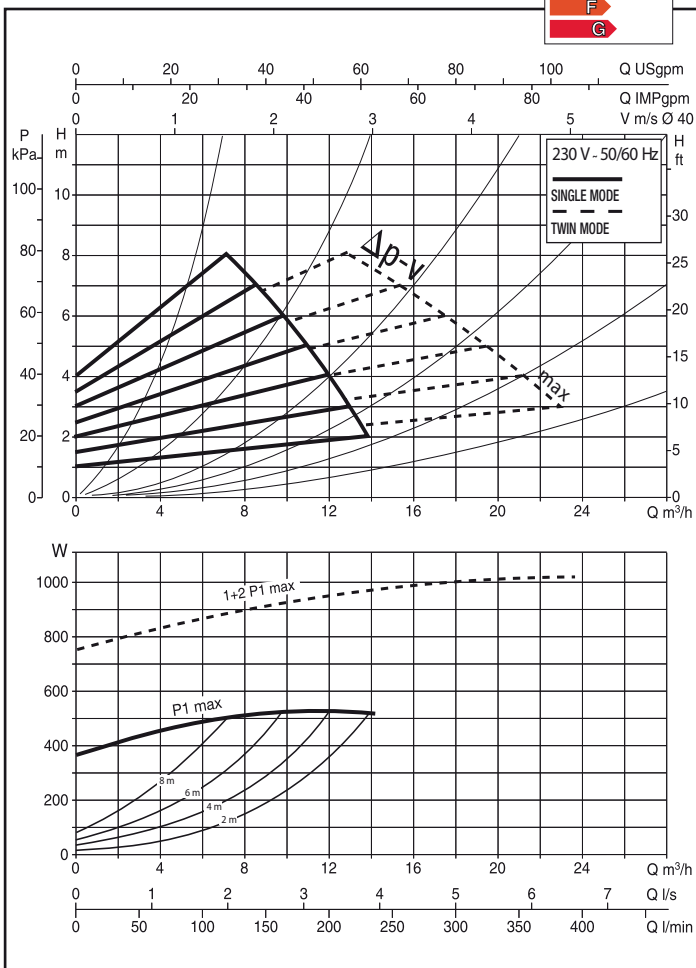

Dimensions

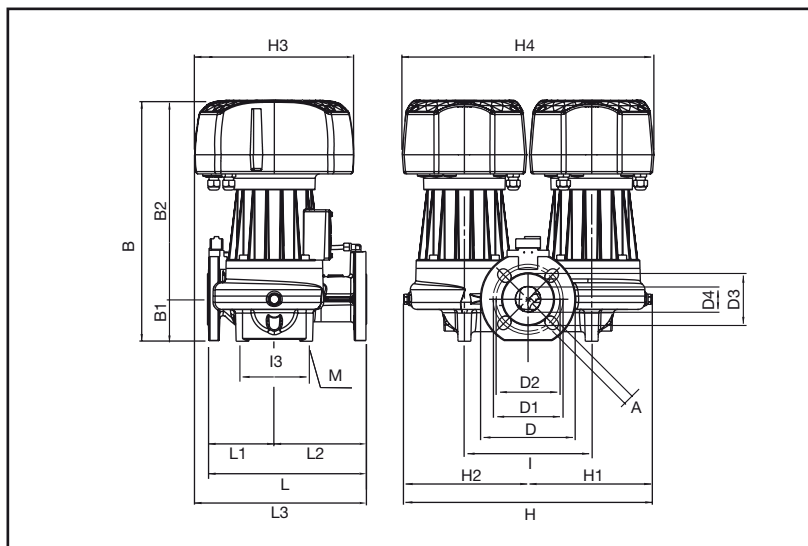

Terminals block layout

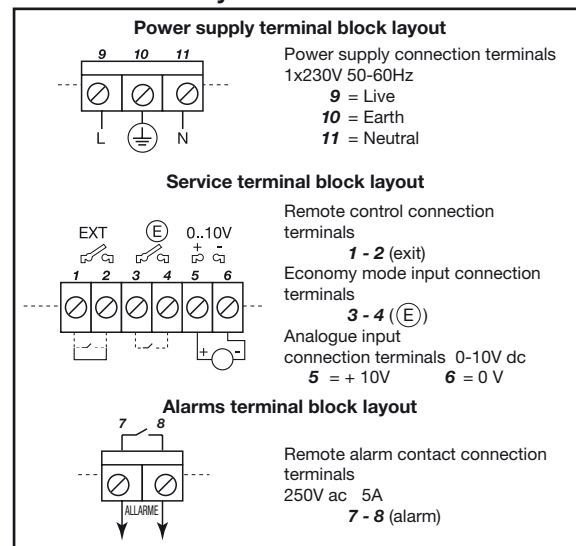

Dimensions

L	L1	L2	L3	A	B	B1	B2	D	D1	D2	D3	D4	I	I1	I2	I3	M	H	H1	H2	H3	H4	VOLUME m ³	WEIGHT Kg
250	105	145	270	18	378	66	312	150	110	100	80	40	200	100	100	100	M12	389	194,5	195	250	396	0,143	42,9

Electrical data

MODEL	VOLTAGE 50/60 Hz	CENTRE DISTANCE mm	FLANGES ON REQUEST	ELECTRICAL DATA		MINIMUM HEAD PRESSURE				
				P1 MAX W	In A	t°	75°	90°	110°	120°
DPH-E 120/250-40	230 V	250	DN 40 - PN 10	528	3	m.t.	6	9	-	23

BPH-E 60/280.50 M

Characteristic curves $\Delta p-c$ (constant)

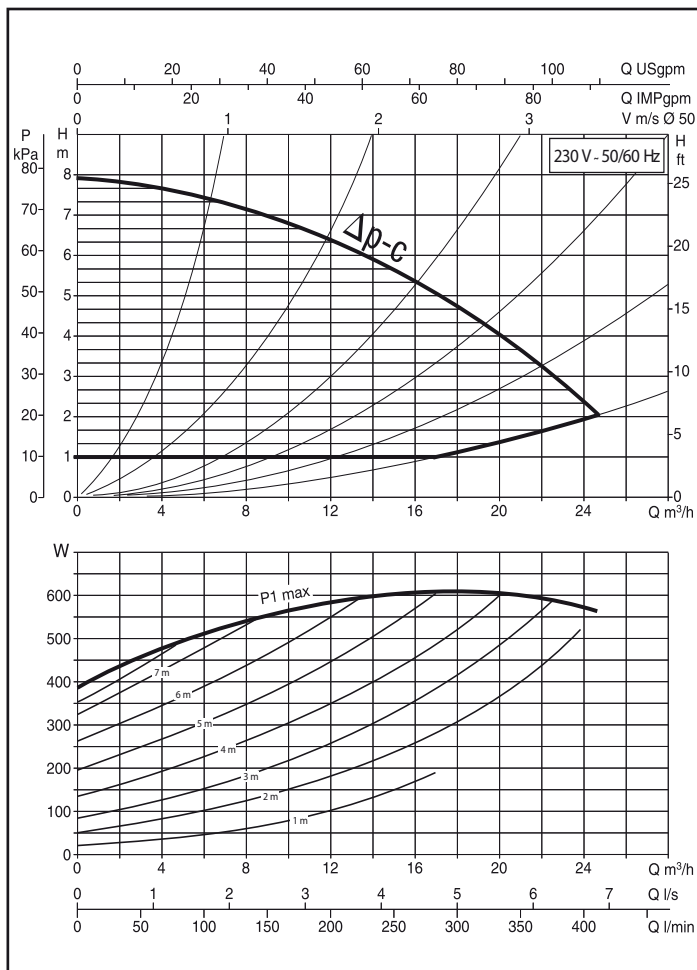

Characteristic curves $\Delta p-v$ (variable)

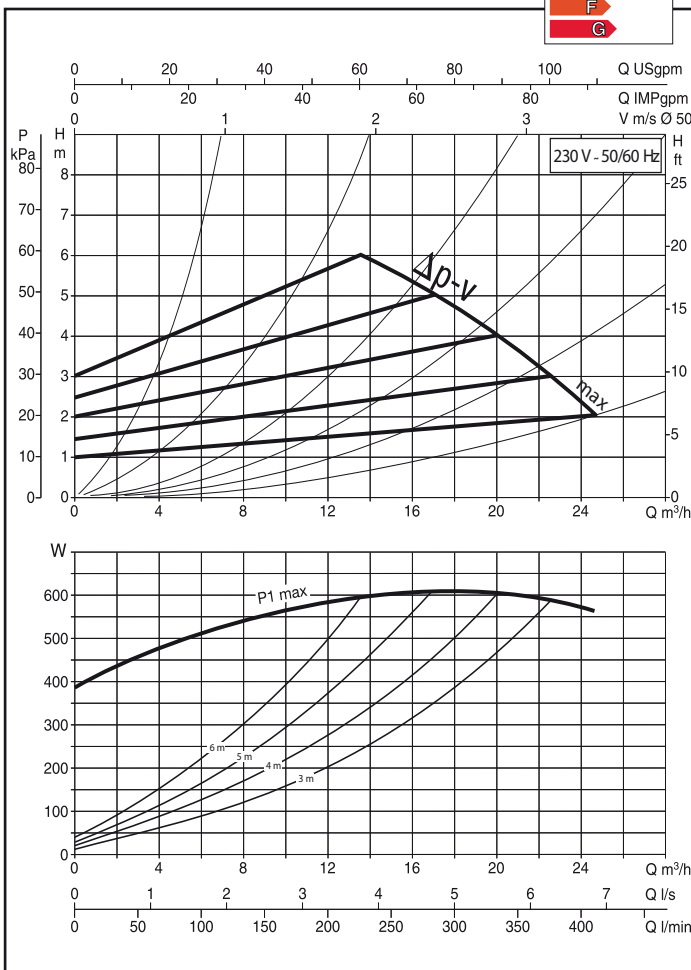

Dimensions

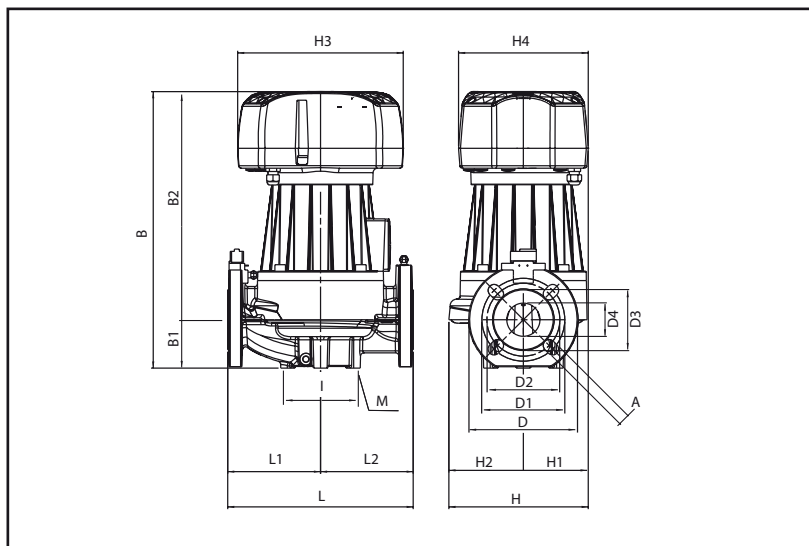

Dimensions

L	L1	L2	A	B	B1	B2	D	D1	D2	D3	D4	I	I1	I2	I3	M	H	H1	H2	H3	H4	VOLUME m ³	WEIGHT Kg
280	140	140	18	417	73	344	165	125	110	90	50	100	-	-	-	M10	210	96	114	250	196	0,087	24,2

Electrical data

MODEL	VOLTAGE 50/60 Hz	CENTRE DISTANCE mm	FLANGES ON REQUEST	ELECTRICAL DATA		MINIMUM HEAD PRESSURE			
				P1 MAX W	I _n A	t° m.t.	75° 4	90° 7,5	110° -
BPH-E 60/280-50	230 V	280	DN 50 - PN 10	606	3,37				

Terminals block layout

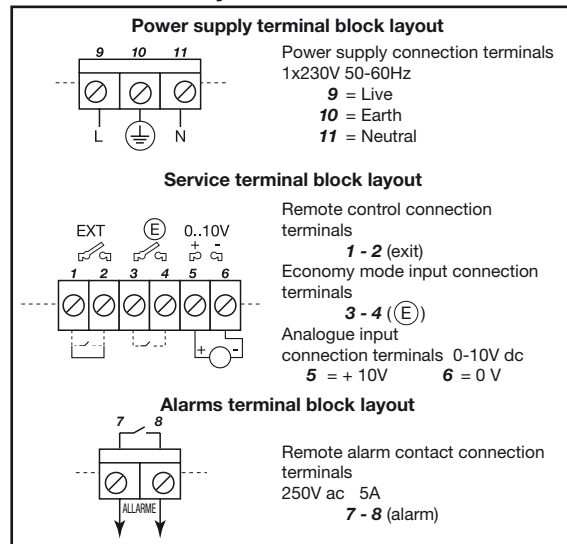

DPH-E 60/280.50 M

Characteristic curves $\Delta p-c$ (constant)

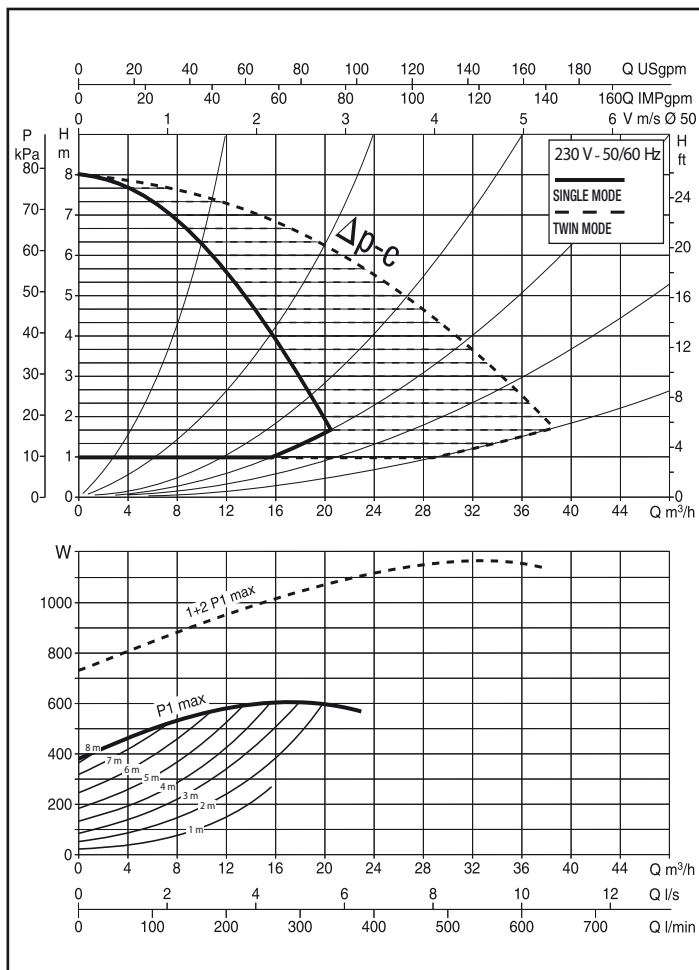

Characteristic curves $\Delta p-v$ (variable)

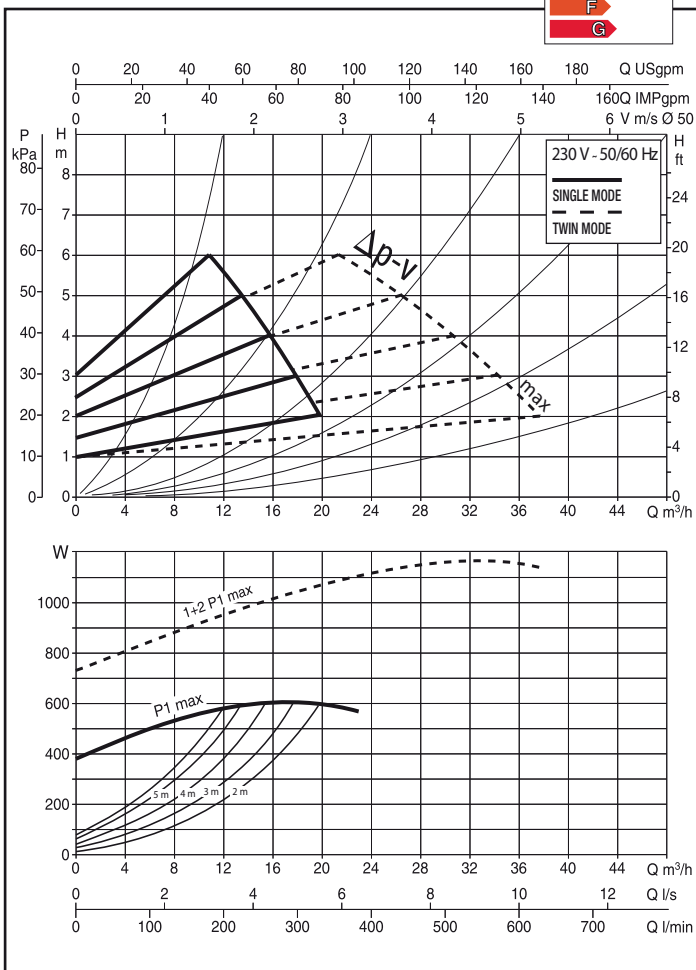

Dimensions

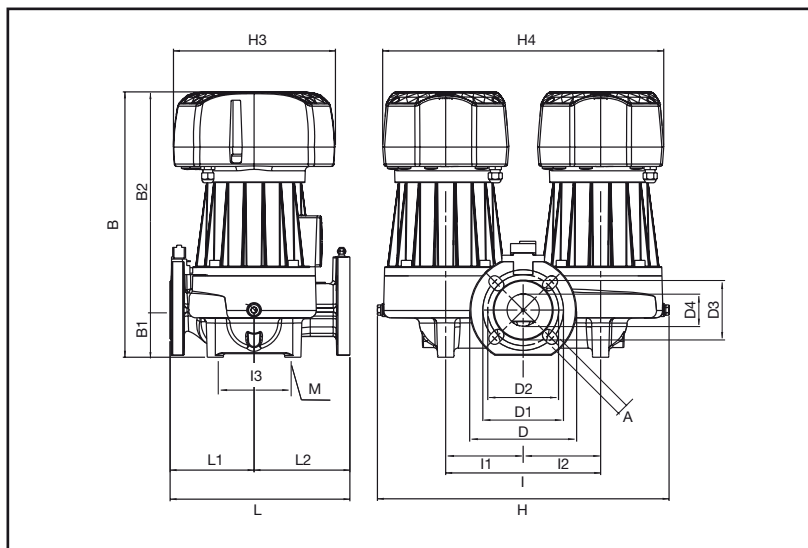

Terminals block layout

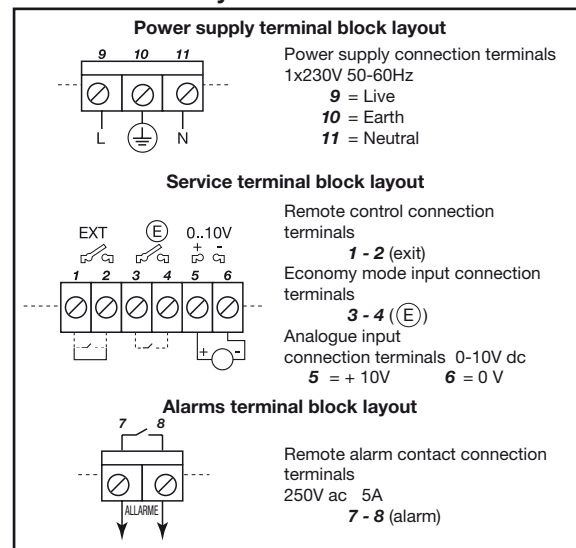

Dimensions

L	L1	L2	A	B	B1	B2	D	D1	D2	D3	D4	I	I1	I2	I3	M	H	H1	H2	H3	H4	VOLUME m ³	WEIGHT Kg
280	130	150	18	411	73	338	165	125	110	90	50	240	120	120	120	M14	452	226	226	250	436	0,143	67,2

Electrical data

MODEL	VOLTAGE 50/60 Hz	CENTRE DISTANCE mm	FLANGES ON REQUEST	ELECTRICAL DATA		MINIMUM HEAD PRESSURE			
				P1 MAX W	I _n A	t° m.t.	75° 4	90° 7,5	110° -
DPH-E 60/280-50	230 V	280	DN 50 - PN 10	606	3,37				

BPH-E 120/280.50 M

Characteristic curves $\Delta p-c$ (constant)

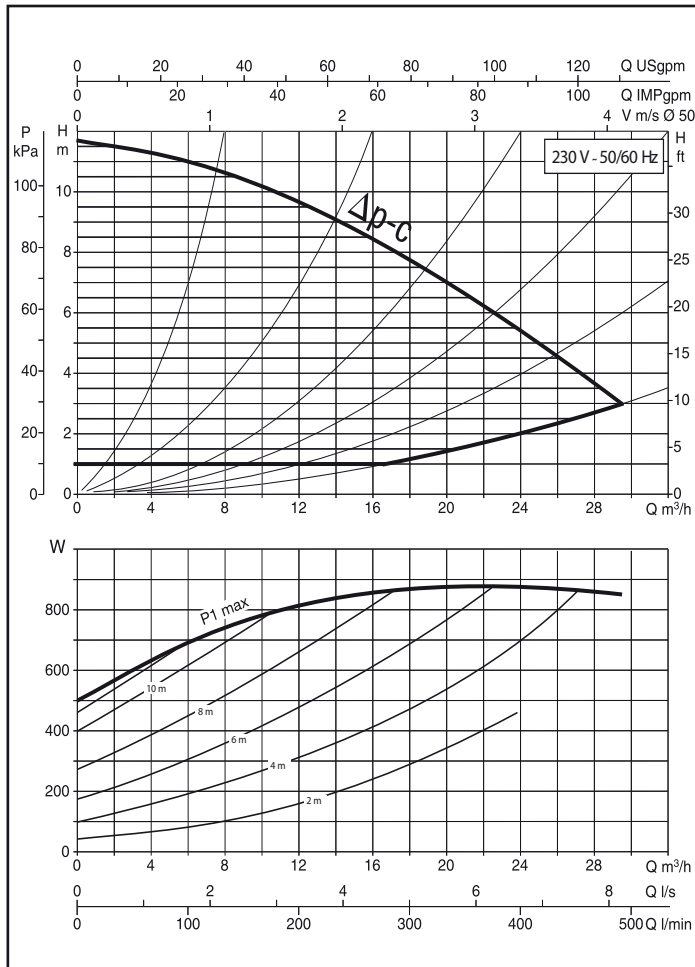

Characteristic curves $\Delta p-v$ (variable)

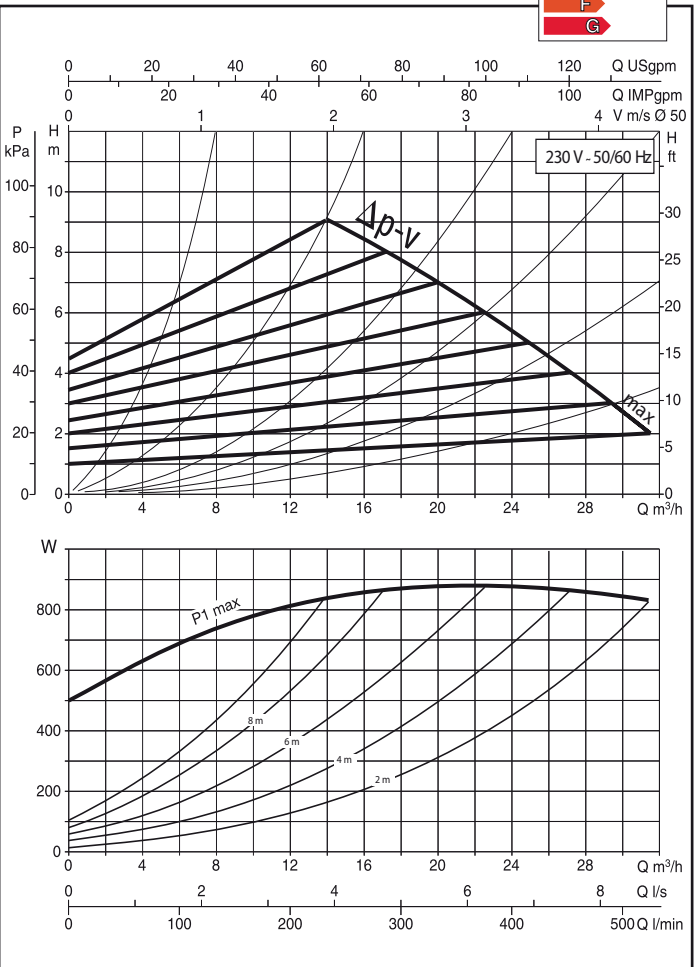

Dimensions

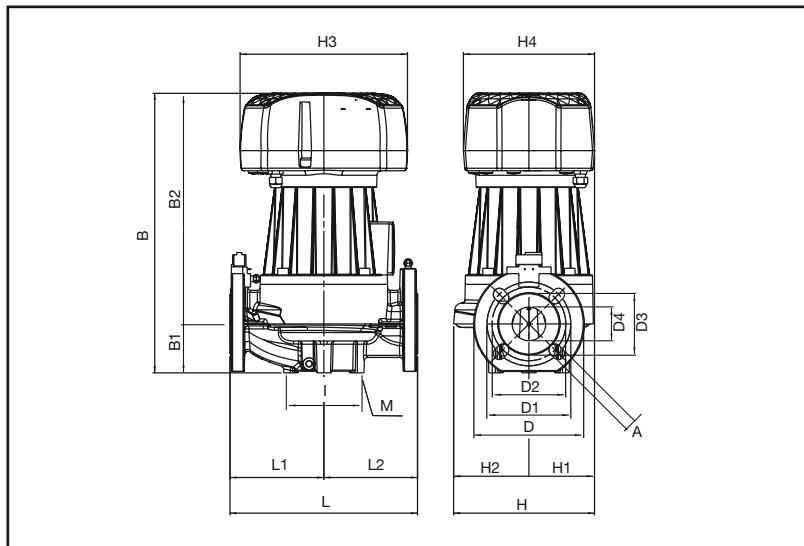

Terminals block layout

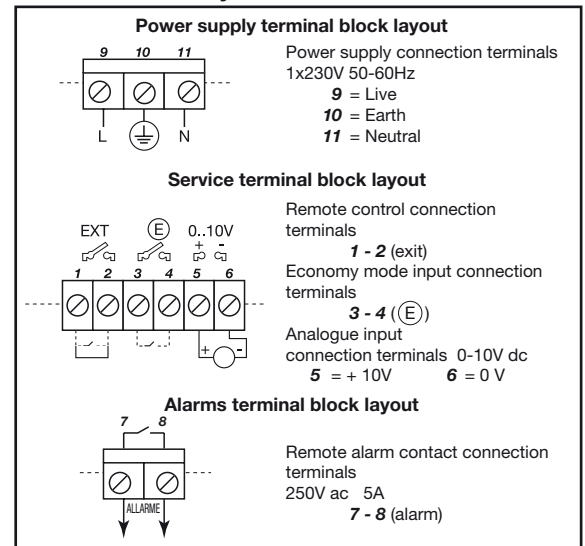

Dimensions

L	L1	L2	A	B	B1	B2	D	D1	D2	D3	D4	I	I1	I2	I3	M	H	H1	H2	H3	H4	VOLUME m ³	WEIGHT Kg
280	140	140	18	417	73	344	165	125	110	90	50	100	-	-	-	M10	210	96	114	250	196	0,087	30,3

Electrical data

MODEL	VOLTAGE 50/60 Hz	CENTRE DISTANCE mm	FLANGES ON REQUEST	ELECTRICAL DATA		MINIMUM HEAD PRESSURE				
				P1 MAX W	I _n A	t° m.t.	75°	90°	110°	120°
BPH-E 120/280-50	230 V	280	DN 50 - PN 10	893	4,84	2	5	-	20	

DPH-E 120/280.50 M

Characteristic curves Δp -c (constant)

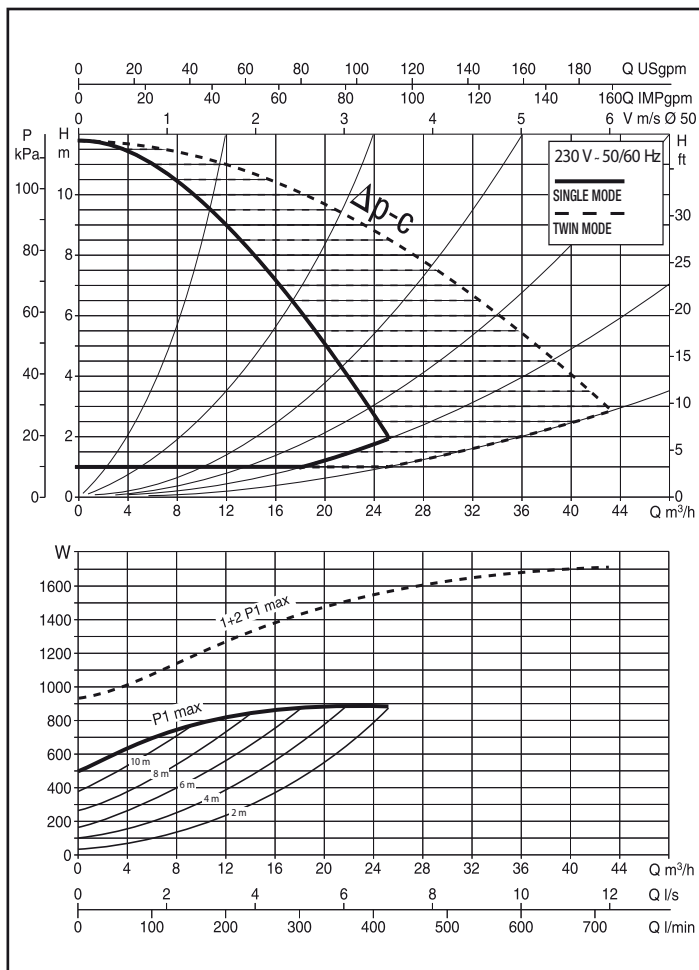

Characteristic curves Δp -v (variable)

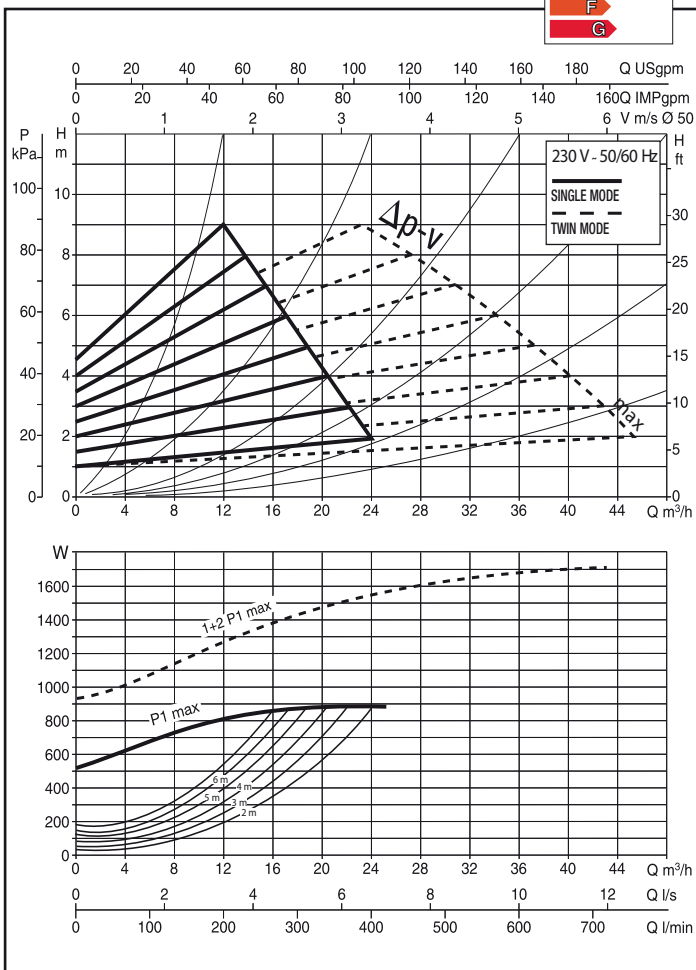

Dimensions

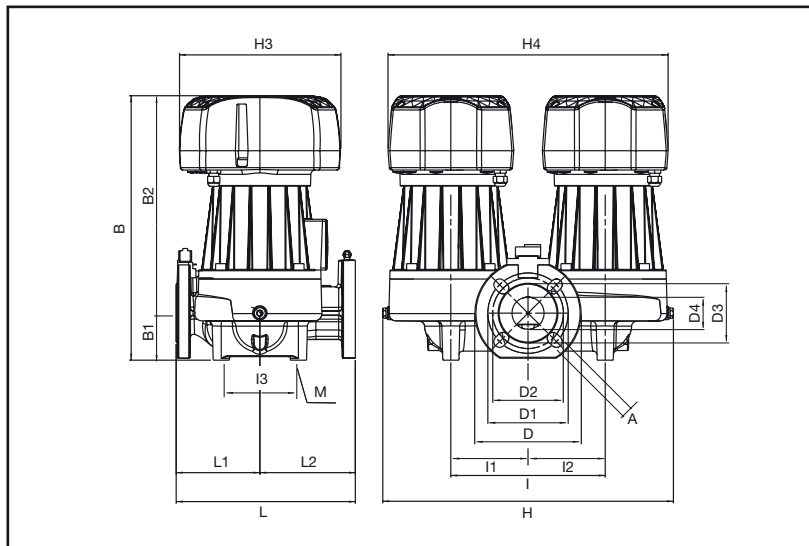

Dimensions

L	L1	L2	A	B	B1	B2	D	D1	D2	D3	D4	I	I1	I2	I3	M	H	H1	H2	H3	H4	VOLUME m ³	WEIGHT Kg
280	130	150	18	411	73	338	165	125	110	90	50	240	120	120	120	M14	452	226	226	250	436	0,143	67,2

Electrical data

MODEL	VOLTAGE 50/60 Hz	CENTRE DISTANCE mm	FLANGES ON REQUEST	ELECTRICAL DATA		MINIMUM HEAD PRESSURE			
				P1 MAX W	I _n A	t° m.t.	75°	90°	110°
DPH-E 120/280-50	230 V	280	DN 50 - PN 10	893	4,84	2	5	-	20

Terminals block layout

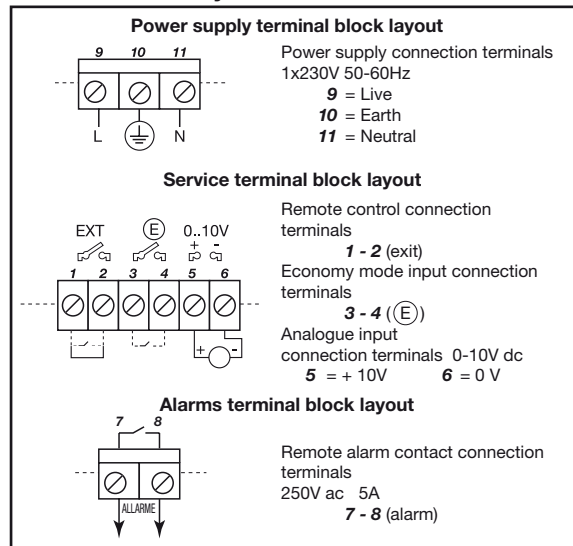

BPH-E 180/280.50 M

Characteristic curves $\Delta p-c$ (constant)

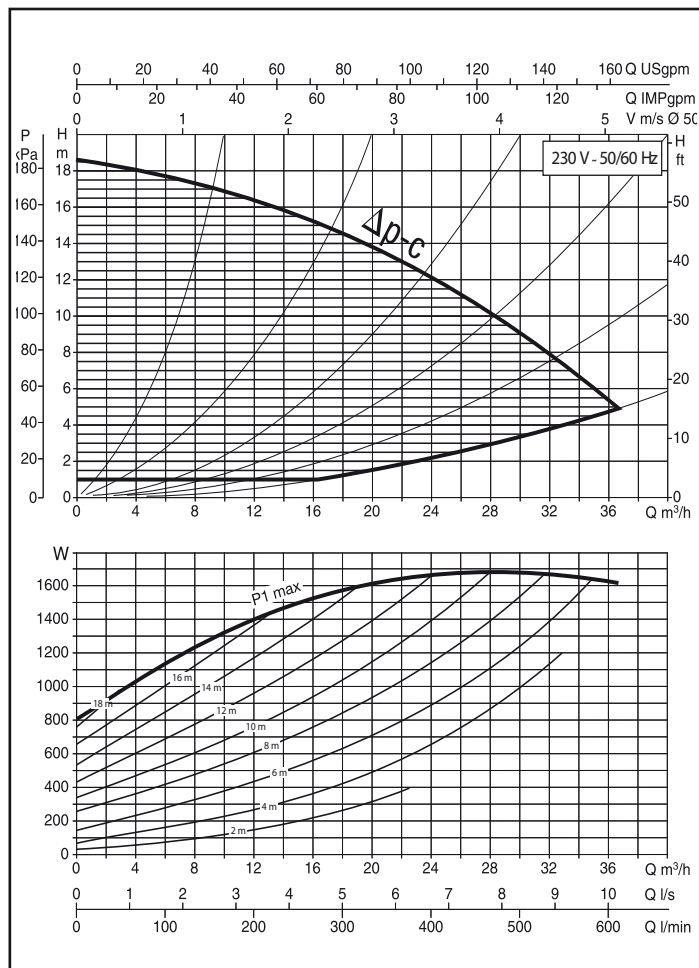

Characteristic curves $\Delta p-v$ (variable)

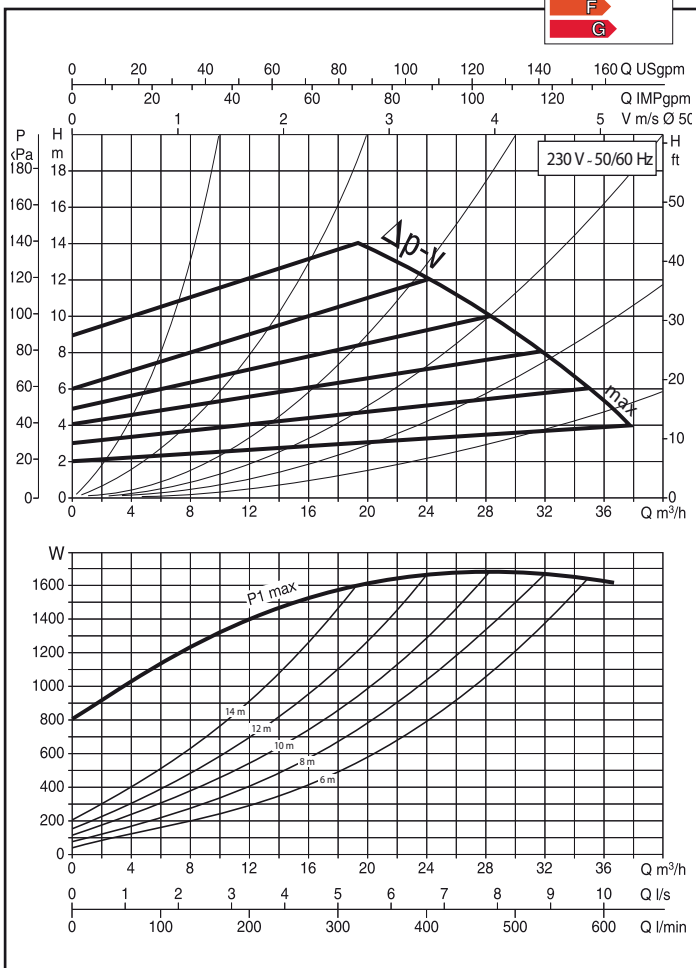

Dimensions

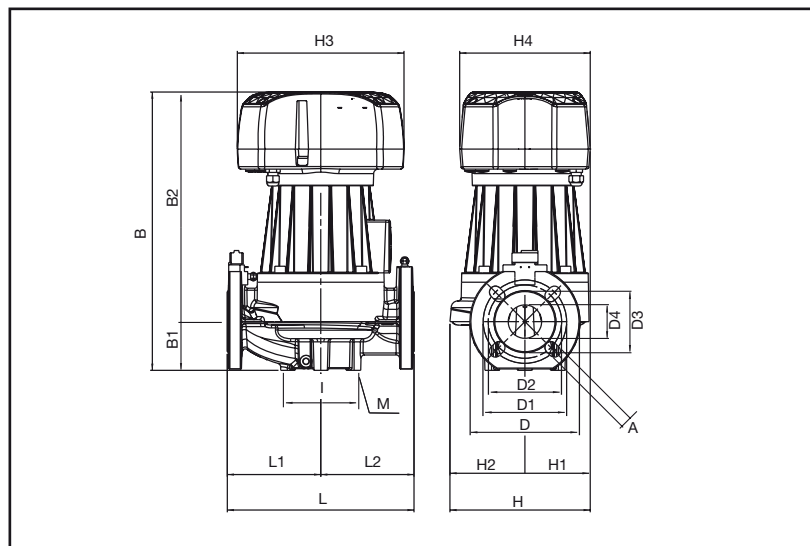

Terminals block layout

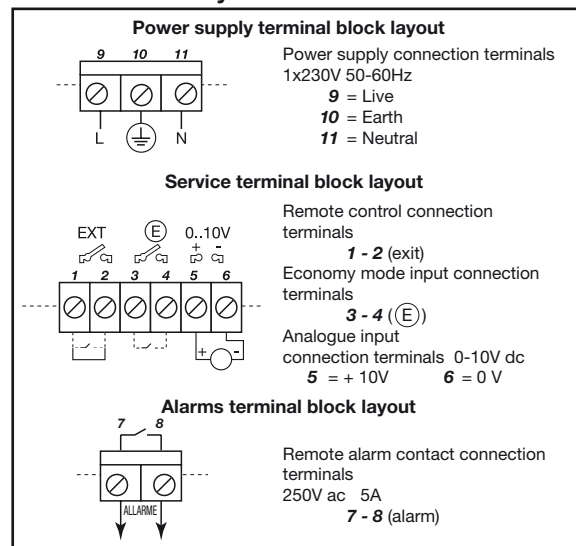

Dimensions

L	L1	L2	A	B	B1	B2	D	D1	D2	D3	D4	I	I1	I2	I3	M	H	H1	H2	H3	H4	VOLUME m ³	WEIGHT Kg
280	140	140	18	467	73	394	165	125	110	90	50	100	-	-	-	M10	210	96	114	250	196	0,087	30,3

Electrical data

MODEL	VOLTAGE 50/60 Hz	CENTRE DISTANCE mm	FLANGES ON REQUEST	ELECTRICAL DATA		MINIMUM HEAD PRESSURE				
				P1 MAX W	I _n A	t° m.t.	75°	90°	110°	120°
BPH-E 180/280-50	230 V	280	DN 50 - PN 10	1693	9,2	2	5	-	20	

DPH-E 180/280.50 M

Characteristic curves $\Delta p-c$ (constant)

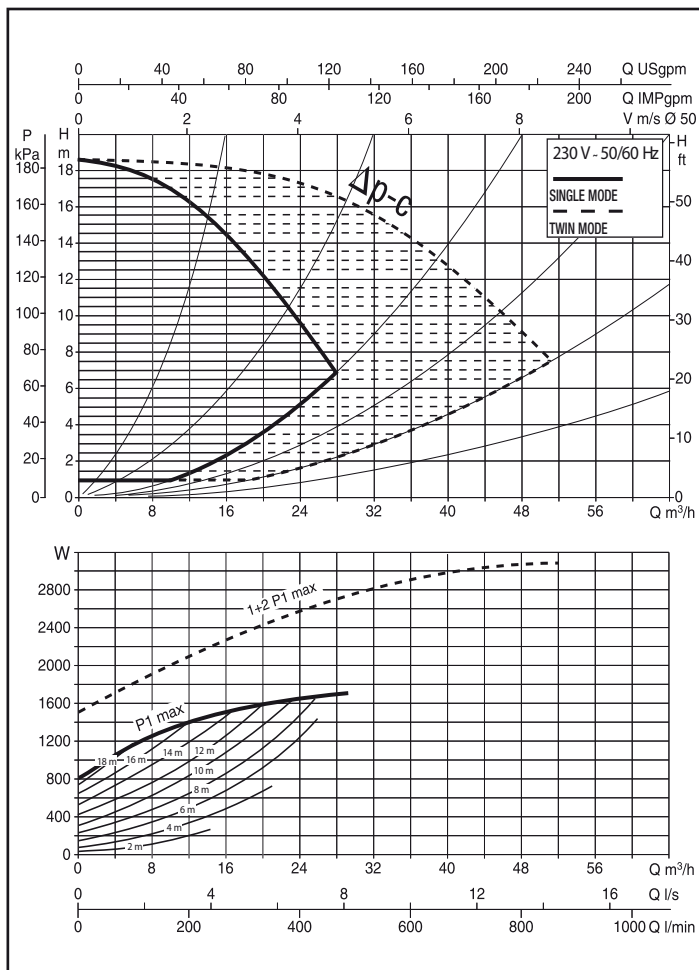

Characteristic curves $\Delta p-v$ (variable)

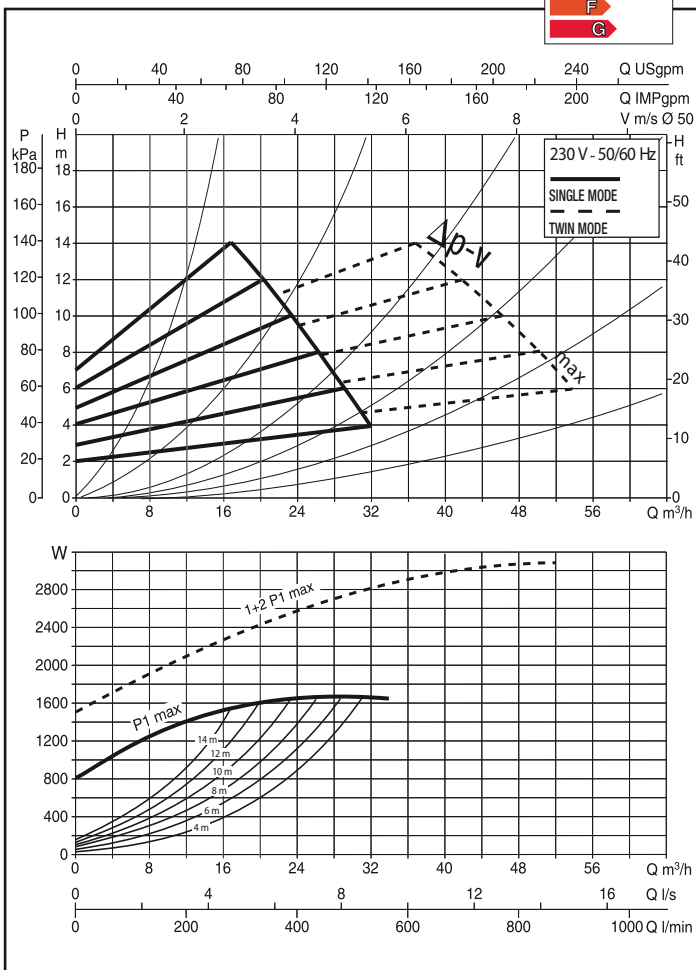

Dimensions

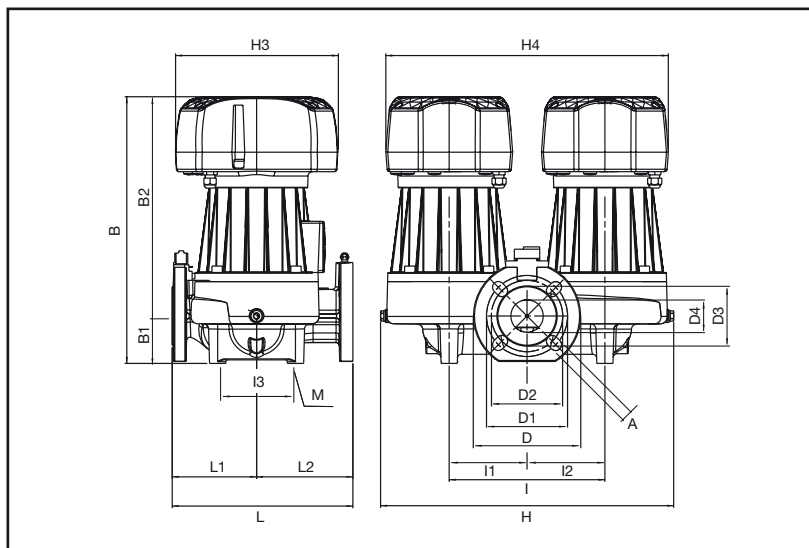

Terminals block layout

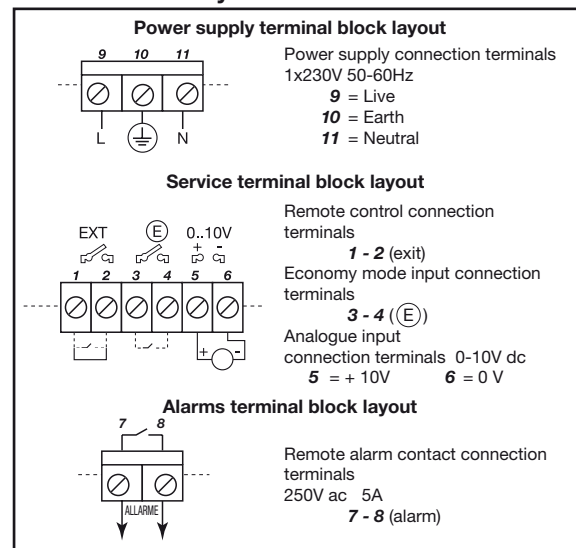

Dimensions

L	L1	L2	A	B	B1	B2	D	D1	D2	D3	D4	I	I1	I2	I3	M	H	H1	H2	H3	H4	VOLUME m³	WEIGHT Kg
280	130	150	18	461	73	388	165	125	110	90	50	240	120	120	120	M14	452	226	226	250	436	0,143	73,2

Electrical data

MODEL	VOLTAGE 50/60 Hz	CENTRE DISTANCE mm	FLANGES ON REQUEST	ELECTRICAL DATA		MINIMUM HEAD PRESSURE				
				P1 MAX W	In A	t° m.t.	75°	90°	110°	120°
DPH-E 180/280-50	230 V	280	DN 50 - PN 10	1693	9,2	2	5	-	20	

BPH-E 60/340.65 M

Characteristic curves $\Delta p-c$ (constant)

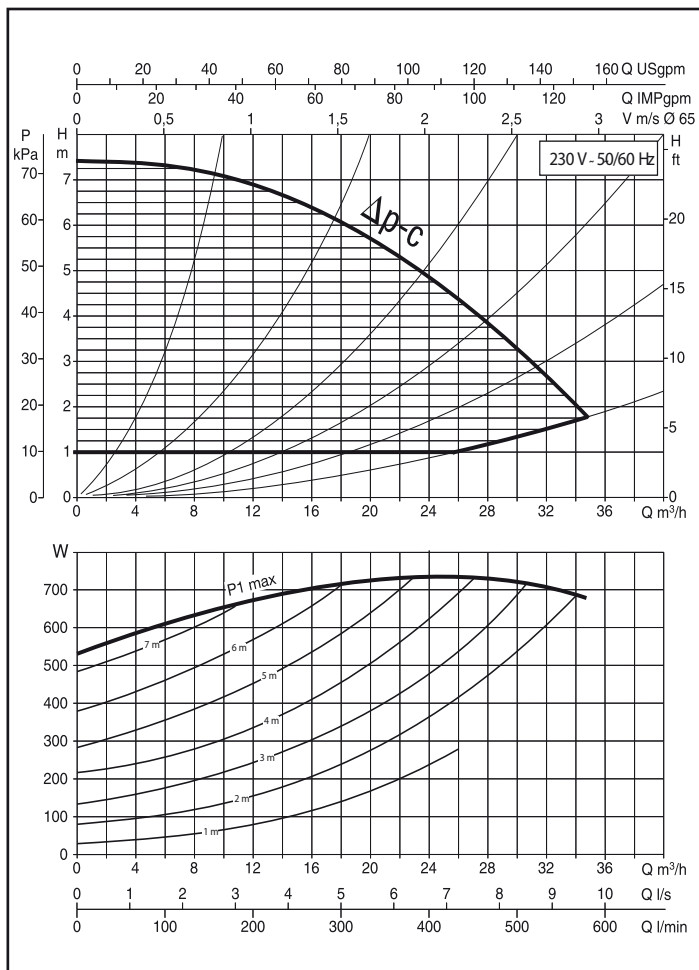

Characteristic curves $\Delta p-v$ (variable)

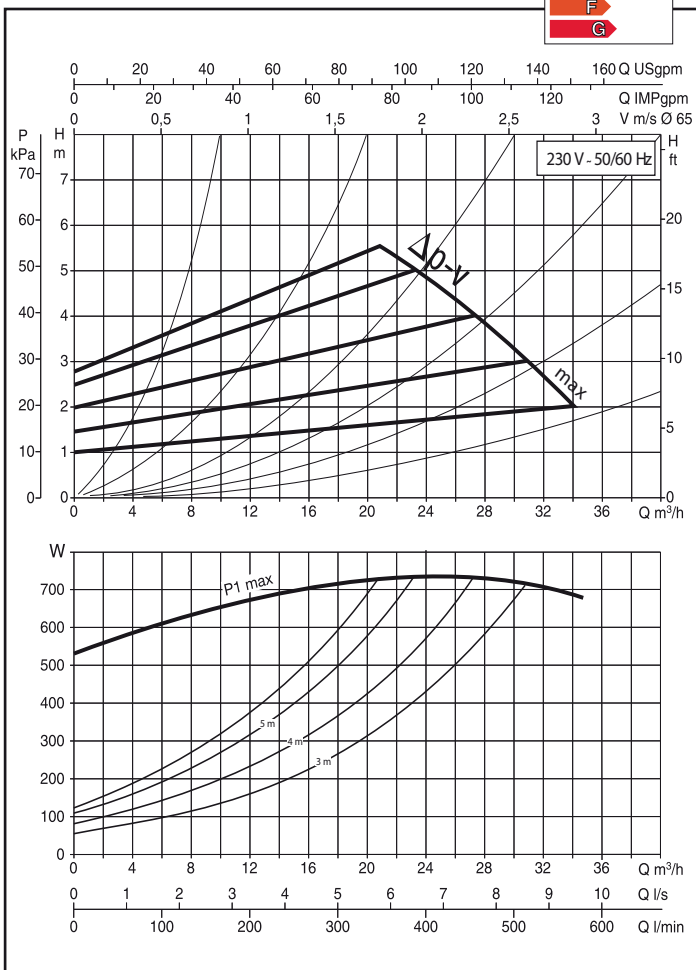

Dimensions

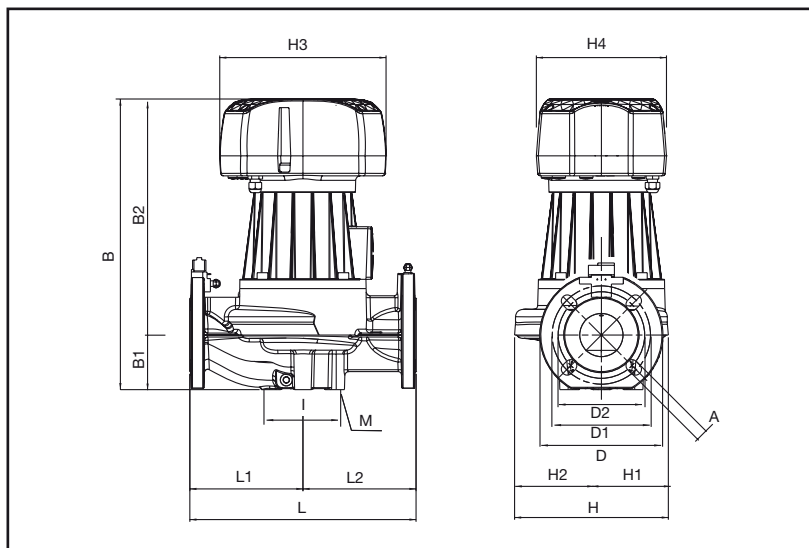

Terminals block layout

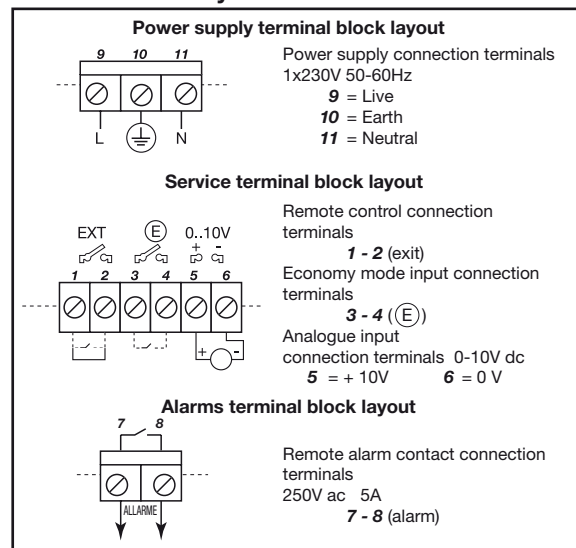

Dimensions

L	L1	L2	A	B	B1	B2	D	D1	D2	D3	D4	I	I1	I2	I3	M	H	H1	H2	H3	H4	VOLUME m ³	WEIGHT Kg
340	170	170	18	437	82	355	185	145	130	110	65	100	-	-	-	M12	231	100	131	250	196	0,087	34,8

Electrical data

MODEL	VOLTAGE 50/60 Hz	CENTRE DISTANCE mm	FLANGES ON REQUEST	ELECTRICAL DATA		MINIMUM HEAD PRESSURE				
				P1 MAX W	I _n A	t° m.t.	75°	90°	110°	120°
BPH-E 60/340-65	230 V	340	DN 65 - PN 10	744	4,1	1	4	-	18	

DPH-E 60/340.65 M

Characteristic curves $\Delta p-c$ (constant)

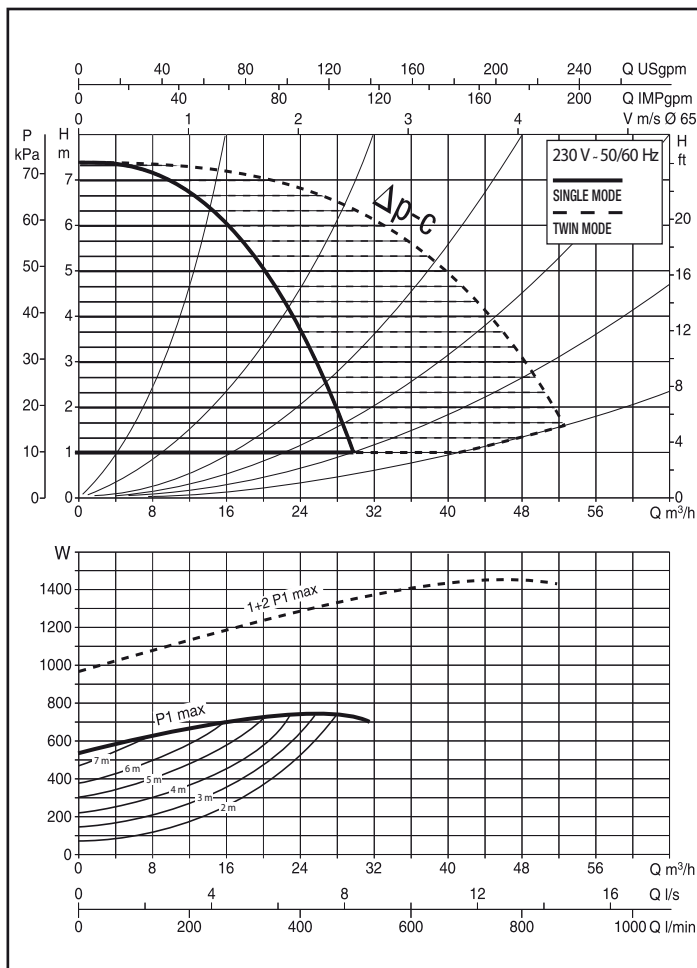

Characteristic curves $\Delta p-v$ (variable)

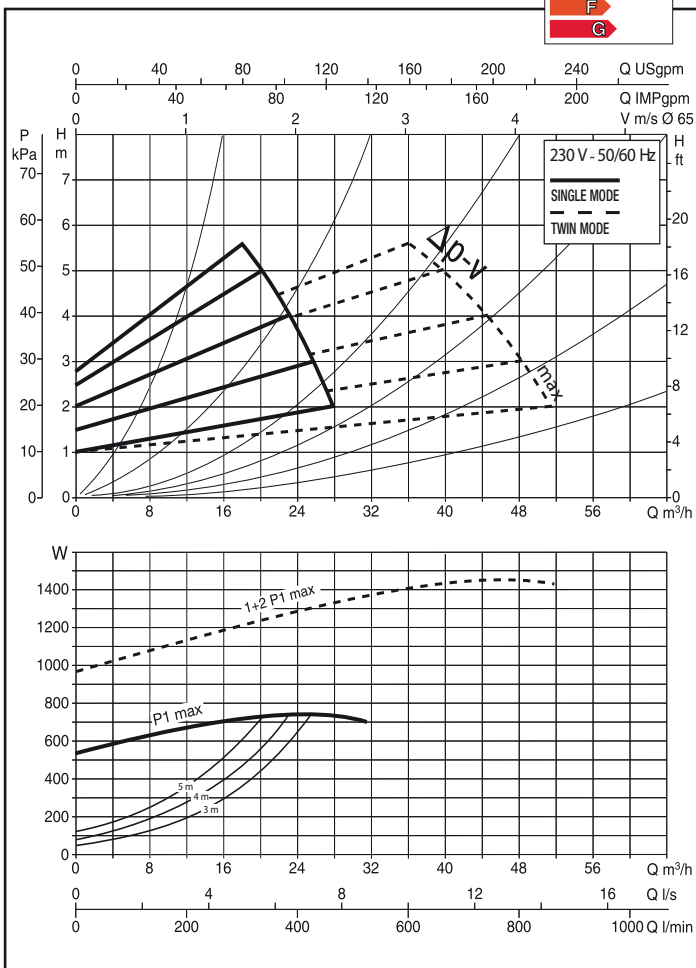

Dimensions

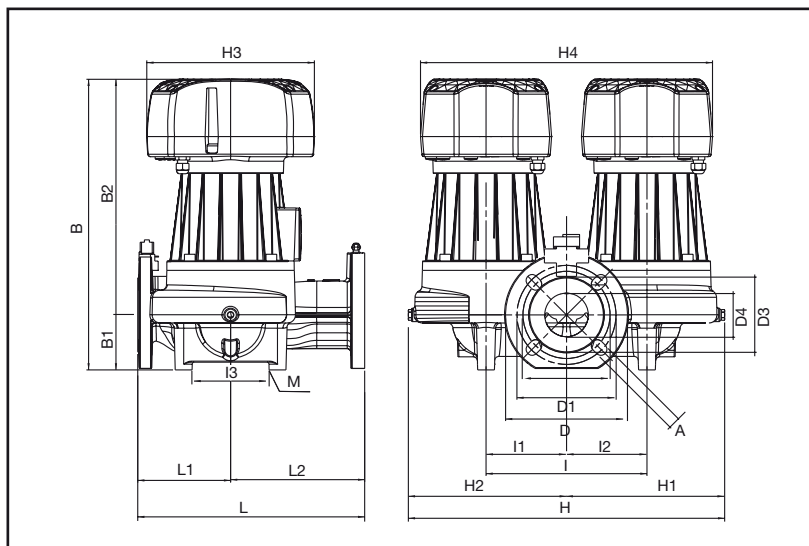

Terminals block layout

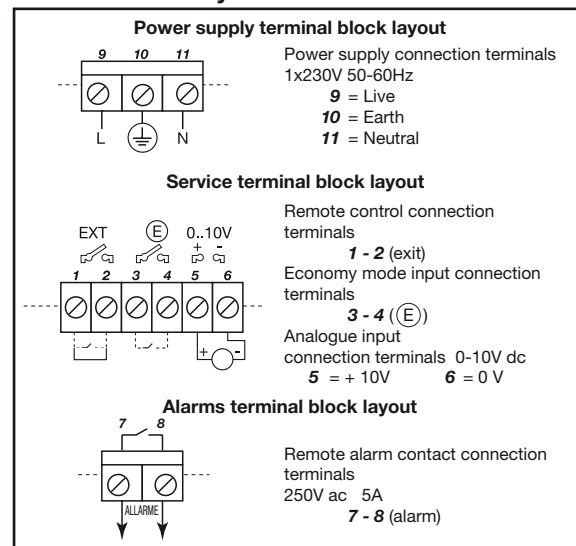

Dimensions

L	L1	L2	A	B	B1	B2	D	D1	D2	D3	D4	I	I1	I2	I3	M	H	H1	H2	H3	H4	VOLUME m ³	WEIGHT Kg
340	138,5	201,5	18	433	82	351	185	145	130	110	65	240	120	120	140	M14	472	236	236	250	436	0,143	72,9

Electrical data

MODEL	VOLTAGE 50/60 Hz	CENTRE DISTANCE mm	FLANGES ON REQUEST	ELECTRICAL DATA		MINIMUM HEAD PRESSURE				
				P1 MAX W	I _n A	t° m.t.	75° 1	90° 4	110° -	120° 18
DPH-E 60/340-65	230 V	340	DN 65 - PN 10	744	4,1					

BPH-E 120/340.65 M

Characteristic curves $\Delta p-c$ (constant)

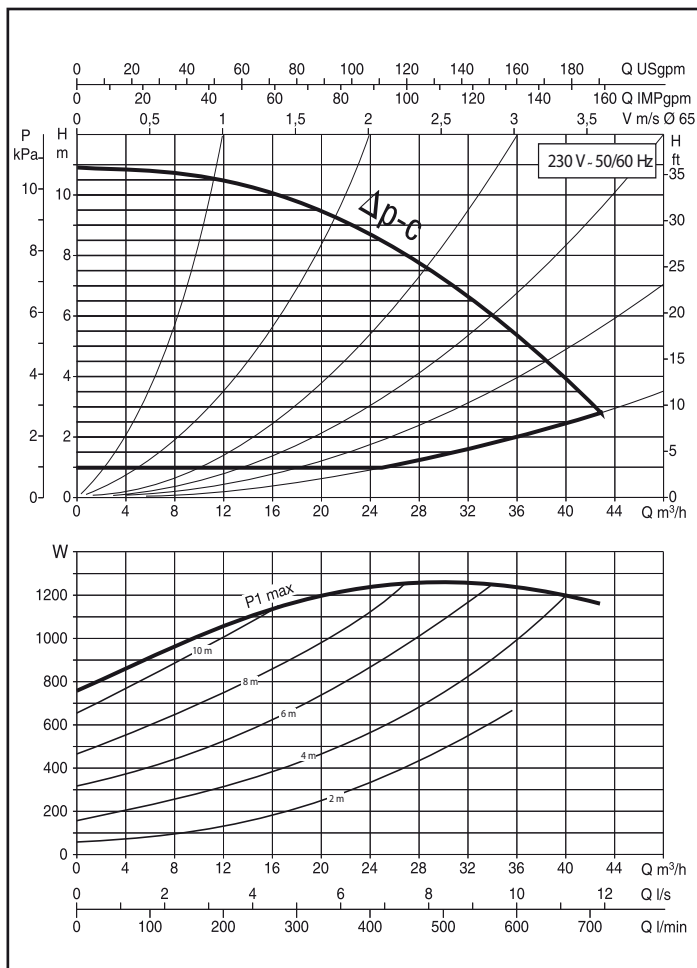

Characteristic curves $\Delta p-v$ (variable)

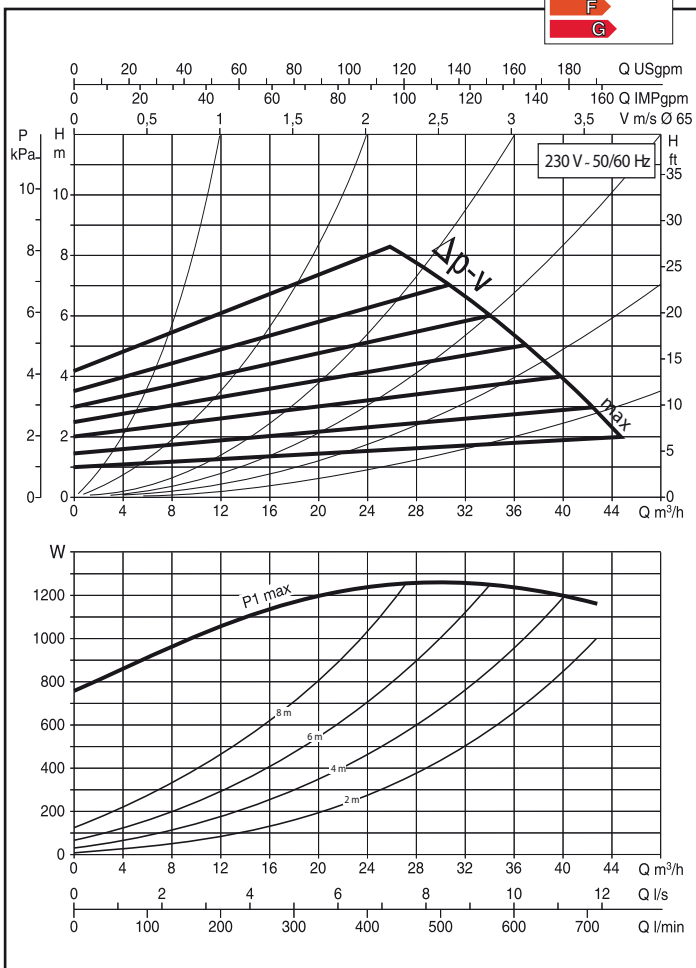

Dimensions

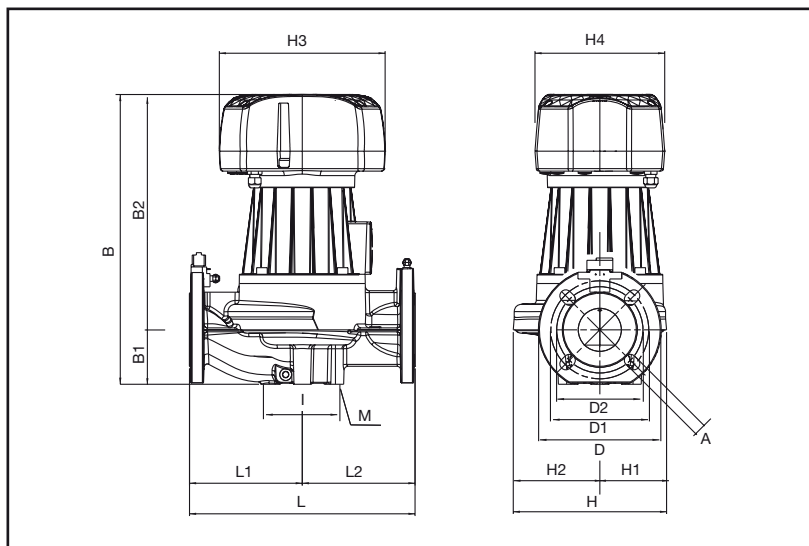

Terminals block layout

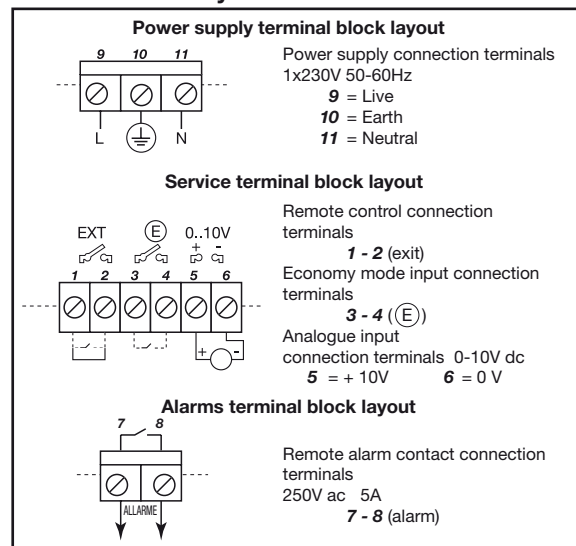

Dimensions

L	L1	L2	A	B	B1	B2	D	D1	D2	D3	D4	I	I1	I2	I3	M	H	H1	H2	H3	H4	VOLUME m ³	WEIGHT Kg
340	170	170	18	487	82	405	185	145	130	110	65	100	-	-	-	M12	231	100	131	250	196	0,087	36,9

Electrical data

MODEL	VOLTAGE 50/60 Hz	CENTRE DISTANCE mm	FLANGES ON REQUEST	ELECTRICAL DATA		MINIMUM HEAD PRESSURE				
				P1 MAX W	I _n A	t° m.t.	75° 7	90° 11	110° 18	120° -
BPH-E 120/340-65	230 V	340	DN 65 - PN 10	1262	6,72	t° m.t.	75° 7	90° 11	110° 18	120° -

DPH-E 120/340.65 M

Characteristic curves $\Delta p-c$ (constant)

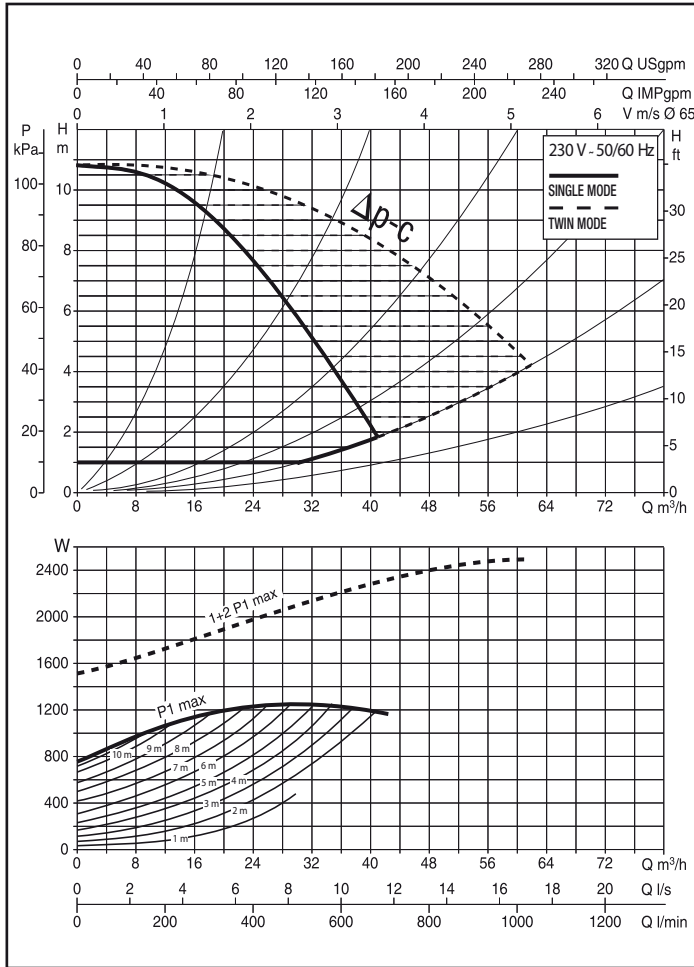

Characteristic curves $\Delta p-v$ (variable)

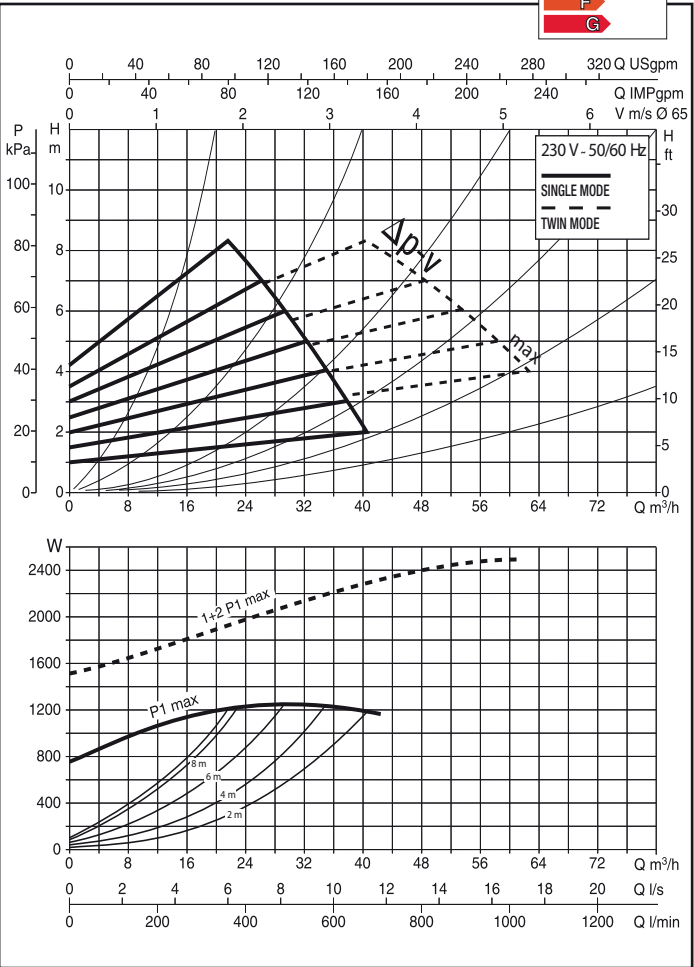

Dimensions

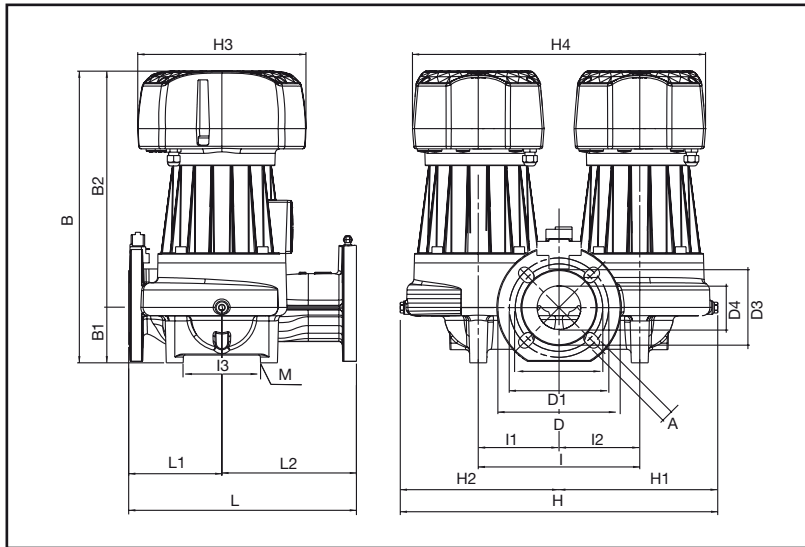

Dimensions

L	L1	L2	A	B	B1	B2	D	D1	D2	D3	D4	I	I1	I2	I3	M	H	H1	H2	H3	H4	VOLUME m ³	WEIGHT Kg
340	138,5	201,5	18	483	82	220	185	145	130	110	65	240	120	120	140	M14	472	236	236	250	436	0,143	77,9

Electrical data

MODEL	VOLTAGE 50/60 Hz	CENTRE DISTANCE mm	FLANGES ON REQUEST	ELECTRICAL DATA		MINIMUM HEAD PRESSURE				
				P1 MAX W	I _n A	t° m.t.	75° 7	90° 11	110° 18	120° -
DPH-E 120/340-65	230 V	340	DN 65 - PN 10	1262	6,72	t°	75°	90°	110°	120°

Terminals block layout

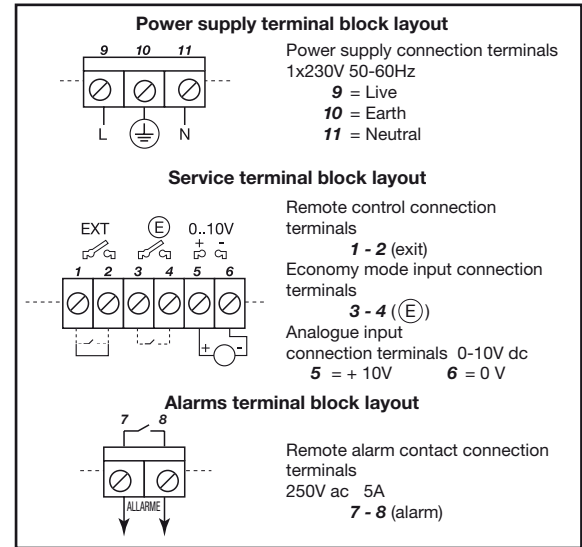

BPH-E 150/340.65 M

Characteristic curves $\Delta p-c$ (constant)

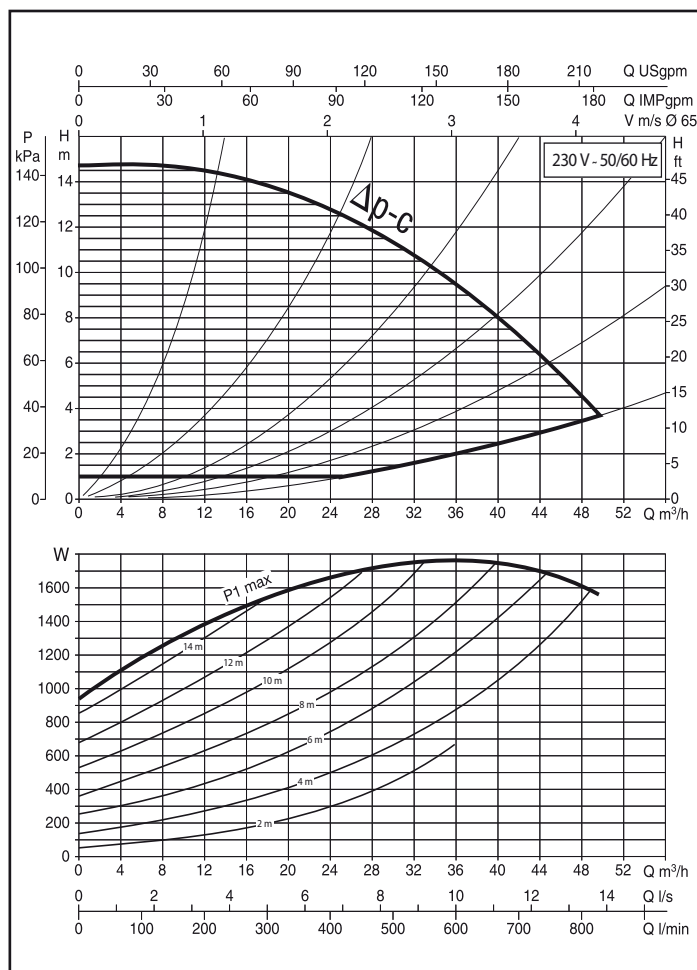

Characteristic curves $\Delta p-v$ (variable)

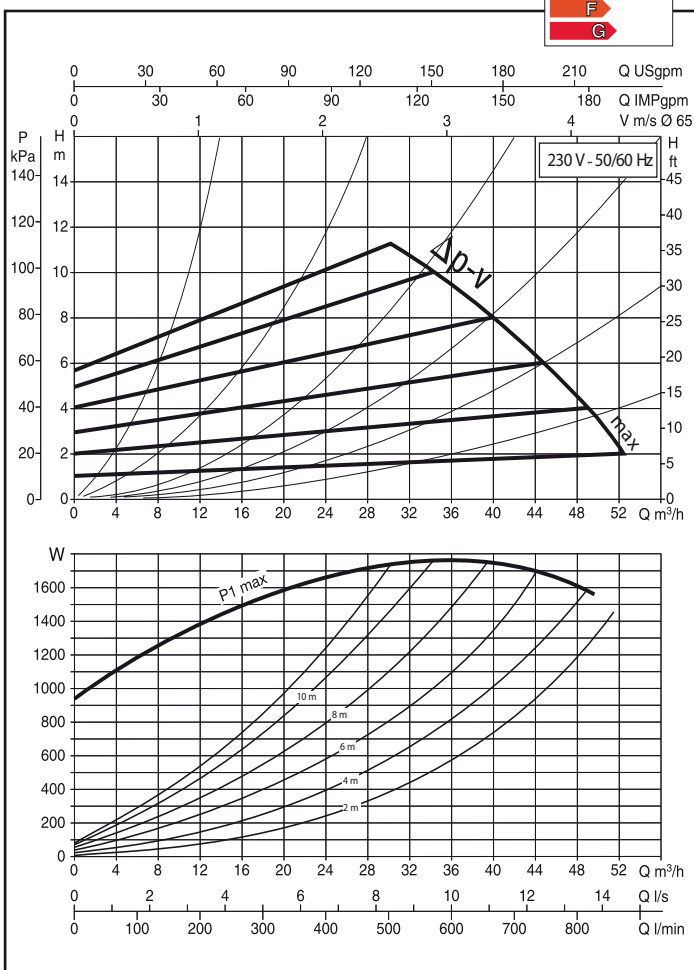

Dimensions

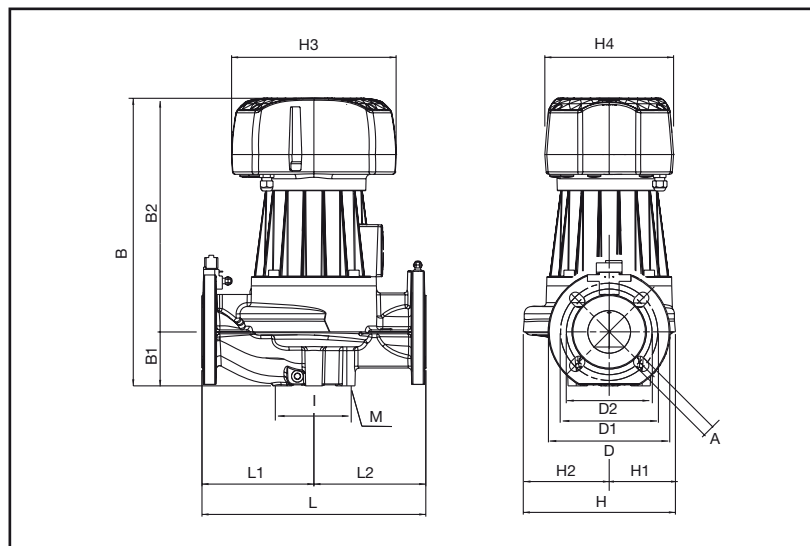

Terminals block layout

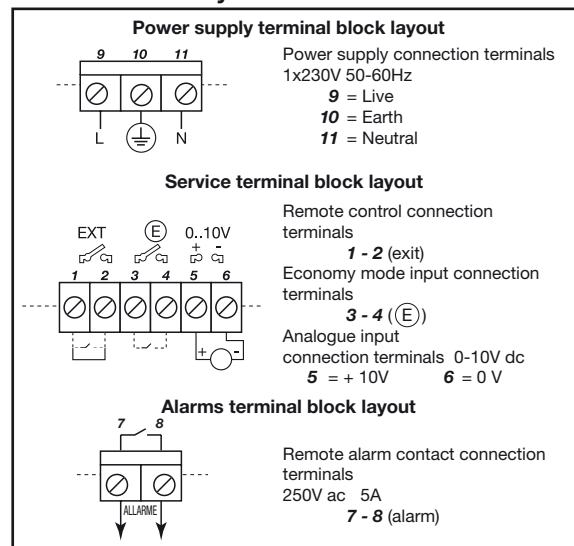

Dimensions

L	L1	L2	A	B	B1	B2	D	D1	D2	D3	D4	I	I1	I2	I3	M	H	H1	H2	H3	H4	VOLUME m ³	WEIGHT Kg
340	170	170	18	487	82	405	185	145	130	110	65	100	-	-	-	M12	231	100	131	250	196	0,087	36,9

Electrical data

MODEL	VOLTAGE 50/60 Hz	CENTRE DISTANCE mm	FLANGES ON REQUEST	ELECTRICAL DATA		MINIMUM HEAD PRESSURE				
				P1 MAX W	I _n A	t° m.t.	75° 7	90° 11	110° 18	120° -
BPH-E 150/340-65	230 V	340	DN 65 - PN 10	1767	9,2					

DPH-E 150/340.65 M

Characteristic curves $\Delta p-c$ (constant)

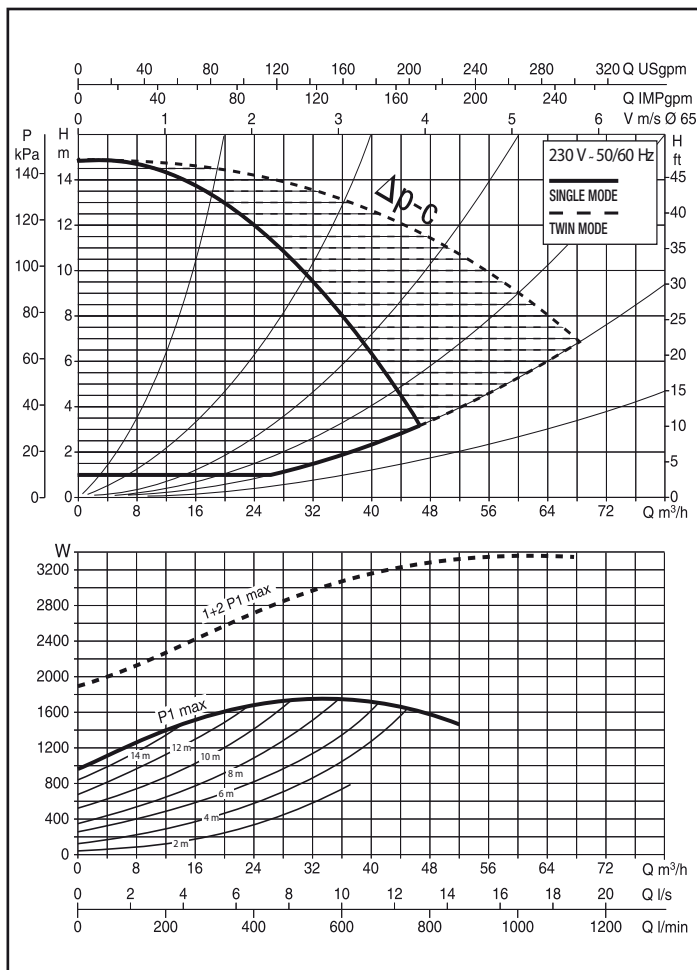

Characteristic curves $\Delta p-v$ (variable)

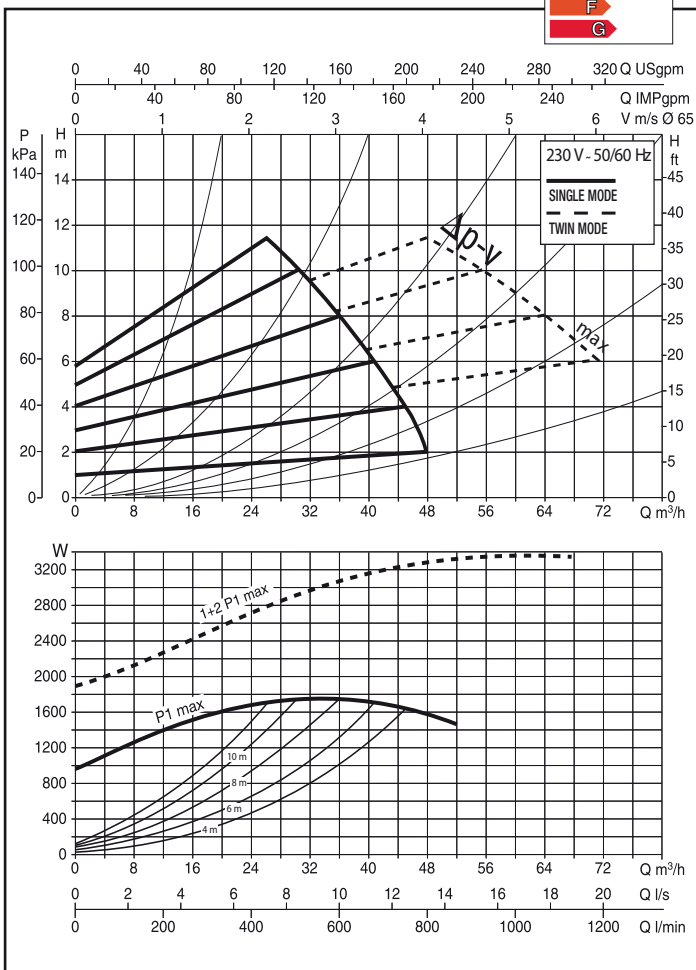

Dimensions

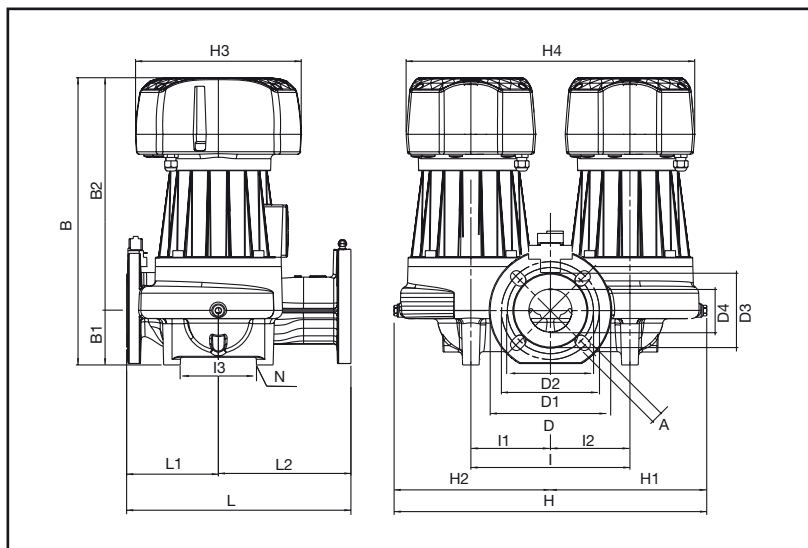

Terminals block layout

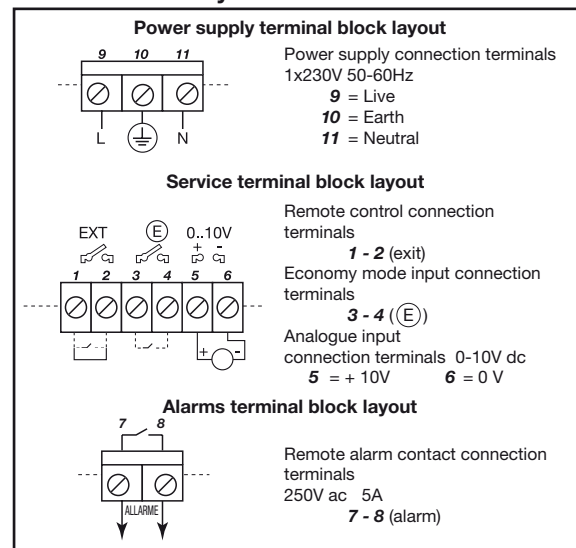

Dimensions

L	L1	L2	A	B	B1	B2	D	D1	D2	D3	D4	I	I1	I2	I3	M	H	H1	H2	H3	H4	VOLUME m ³	WEIGHT Kg
340	138,5	201,5	18	483	82	220	185	145	130	110	65	240	120	120	140	M14	472	236	236	250	436	0,143	77,9

Electrical data

MODEL	VOLTAGE 50/60 Hz	CENTRE DISTANCE mm	FLANGES ON REQUEST	ELECTRICAL DATA		MINIMUM HEAD PRESSURE				
				P1 MAX W	I _n A	t° m.t.	75°	90°	110°	120°
DPH-E 150/340-65	230 V	340	DN 65 - PN 10	1767	9,2	7	11	18	-	-

BPH-E 120/360.80 M

Characteristic curves $\Delta p-c$ (constant)

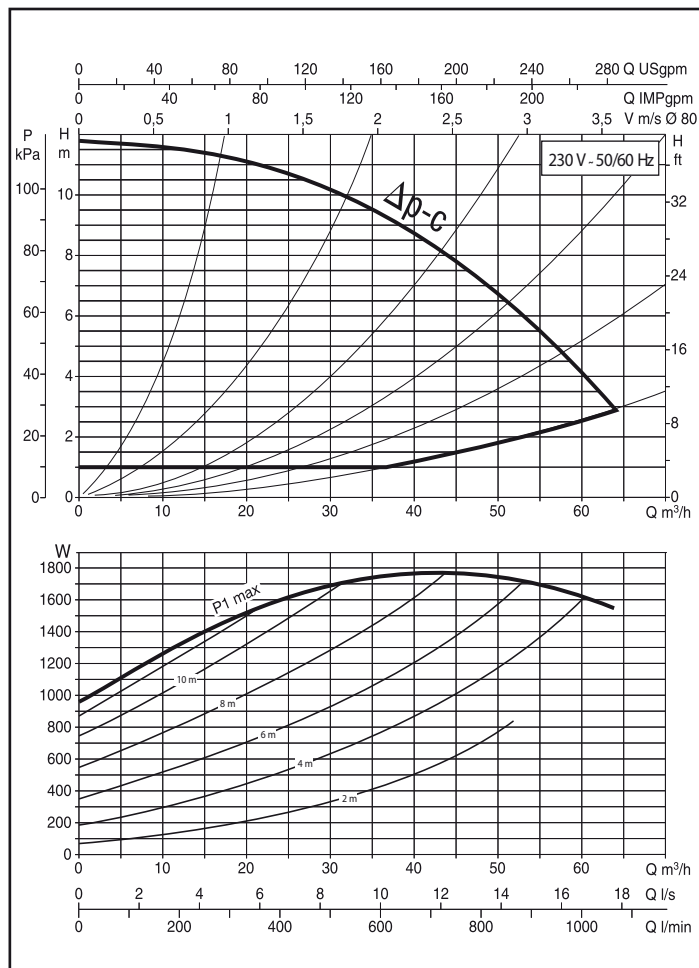

Characteristic curves $\Delta p-v$ (variable)

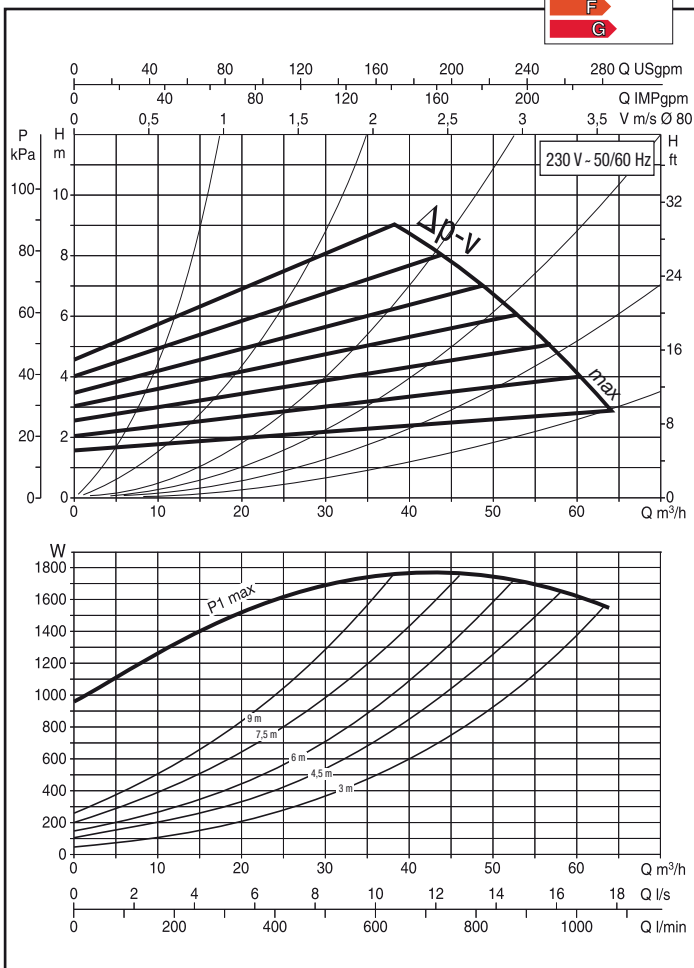

Dimensions

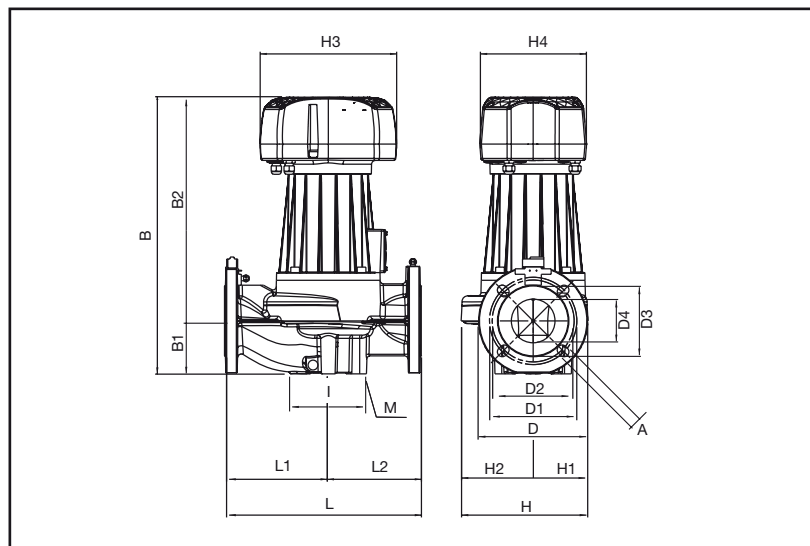

Terminals block layout

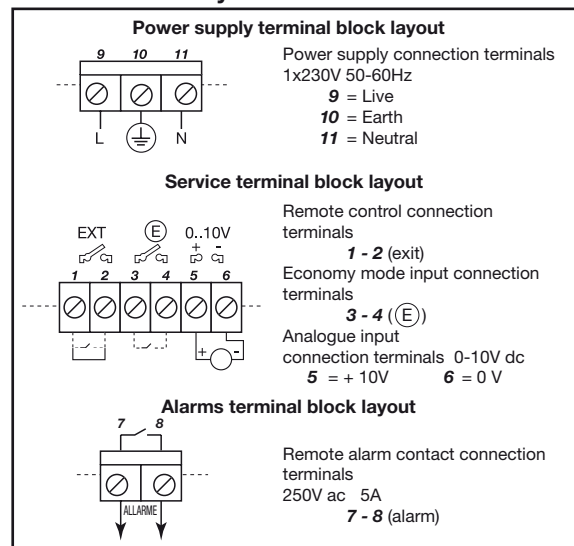

Dimensions

L	L1	L2	A	B	B1	B2	D	D1	D2	D3	D4	I	I1	I2	I3	M	H	H1	H2	H3	H4	VOLUME m ³	WEIGHT Kg
360	190	170	18	506	97	409	200	160	150	130	80	115	-	-	-	M12	232	100	132	250	196	0,087	44,4

Electrical data

MODEL	VOLTAGE 50/60 Hz	CENTRE DISTANCE mm	FLANGES ON REQUEST	ELECTRICAL DATA		MINIMUM HEAD PRESSURE				
				P1 MAX W	I _n A	t° m.t.	75° 6	90° 10	110° -	120° 22
BPH-E 120/360-80	230 V	360	DN 80 - PN 10	1789	9,23	t° m.t.	75° 6	90° 10	110° -	120° 22

DPH-E 120/360.80 M

Characteristic curves $\Delta p-c$ (constant)

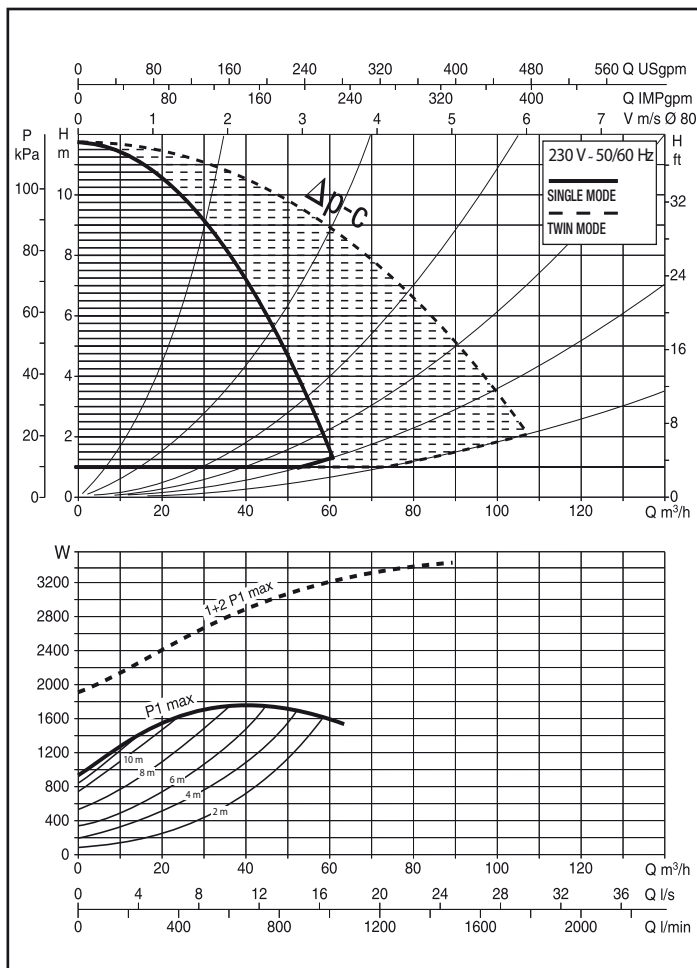

Characteristic curves $\Delta p-v$ (variable)

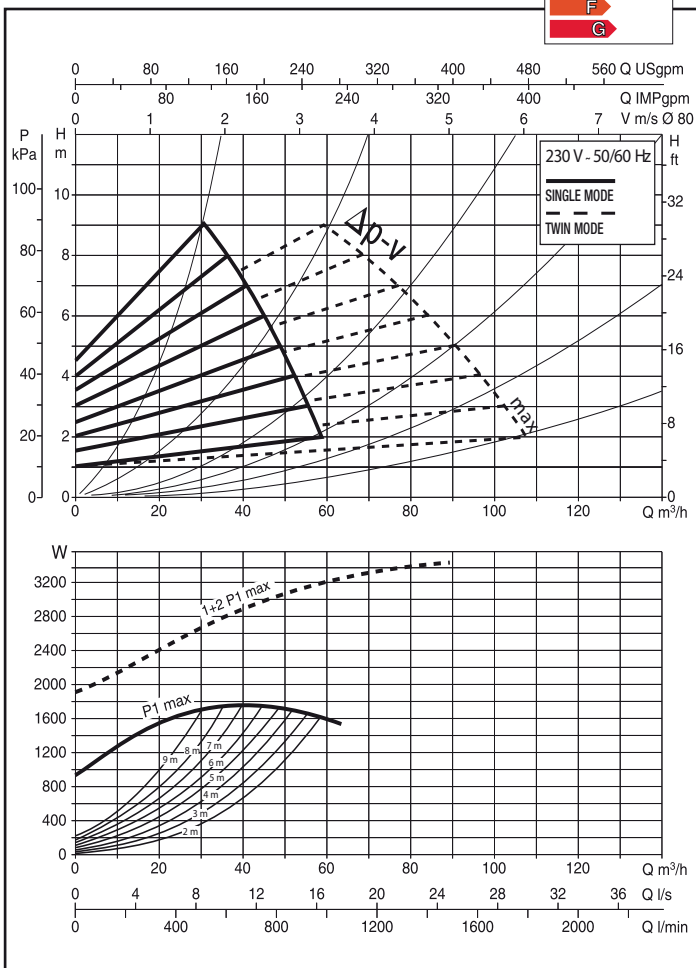

Dimensions

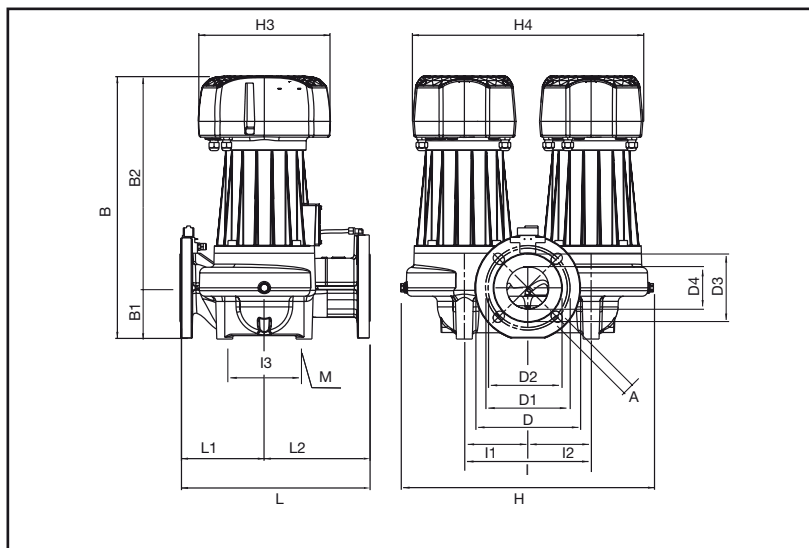

Terminals block layout

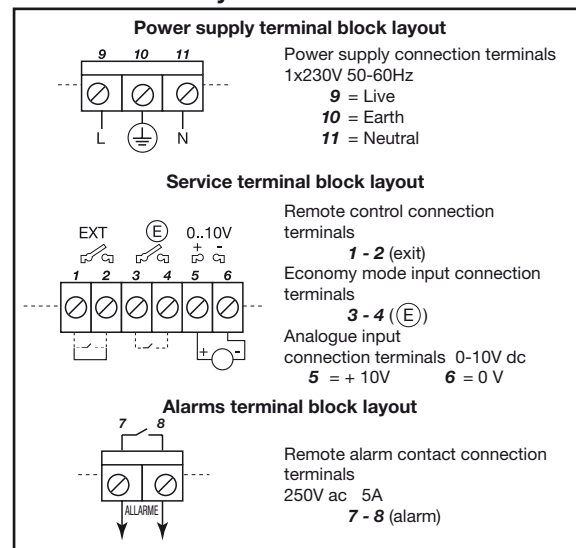

Dimensions

L	L1	L2	A	B	B1	B2	D	D1	D2	D3	D4	I	I1	I2	I3	M	H	H1	H2	H3	H4	VOLUME m ³	WEIGHT Kg
360	160	200	18	497	97	400	200	160	150	130	80	240	120	120	150	M14	478	239	239	250	436	0,143	89,9

Electrical data

MODEL	VOLTAGE 50/60 Hz	CENTRE DISTANCE mm	FLANGES ON REQUEST	ELECTRICAL DATA		MINIMUM HEAD PRESSURE				
				P1 MAX W	I _n A	t° m.t.	75° 6	90° 10	110° -	120° 22
DPH-E 120/360-80	230 V	360	DN 80 - PN 10	1789	9,20					



PUMP PERFORMANCE

DAB PUMPS Spa - Via Marco Polo, 14 - 35035 Mestrino PADOVA - Italia - Tel. +39-049-9048811 r.a. - Fax +39-049-9048847 - www.dabpumps.com

Sales Export dept:

Ph: +39-049-9048895-96-97

Fax +39-049-9048900

Customer Technical Assistance:

Ph. +39-049-9048911

Fax +39-049-9048920